

Product Specification

M7300CD Variable Gain EDFA, 17 dBm OP, 15-30 dB Gain

PN: FOA-M7300CD-EVG1C-AA002

Document No.: 1213704 Revision: A00

Date: 01-Apr-14

Customer: General

Product Features

- Variable Gain EDFA with control electronics
- APC or AGC control modes
- Flat spectrum over gain range of 15-30 dB
- Output Power up to 17 dBm
- Low noise figure
- Standard 70x90 package
- Standard command protocol according to IEC 61291-6-1
- Low power dissipation
- RoHS compliant and lead free
- Class 1M* laser safety classification



Applications

- Regional, metro and access DWDM networks
- ROADM line cards
- Booster, Pre-amp or Inline

The M7300CD Variable Gain (VG) EDFA is a micro processor-controlled module for C-band amplification. It is packaged in a standard 70x90 multi-source amplifier package, meaning that it can be mounted on any line card already designed to accommodate a multi-source EDFA.

The amplifier quickly reacts to network conditions as they unfold, seamlessly adjusting to variations in the system conditions of Metro and Long Haul environments in real-time. It can accommodate a wide variety of network topologies, fiber spans and fiber losses, thereby reducing the number of amplifier types needed for deployment in any given network environment. The amplifier provides gain flattening and low noise figure in all its operational regimes. Its fast AGC allows the amplifier to keep the gain constant also in cases when there is a fast and large change in the input power.

Optical Specification

Parameter		Units	Specification			Notes
			Min.	Typ	Max.	
Wavelength Bandwidth		Nm	1529.5		1564	
Input Power Range	With Transient Suppression		-28		+5	
	Monitoring Only		-38		-28	The lower 3dB range has detection accuracy of +/-1dB
Output Power Range		dBm	-8		17	Signal power, excluding ASE With ASE output is higher.
Saturated Output Power		dBm	17			
Gain range		dB	15		30	
Noise Figure	G=30dB	dB			5.5	At Tilt = 0dB
	G≥27dB	dB			5.7	
	G≥24dB	dB			6.0	
	G≥21dB	dB			6.6	
	G≥18dB	dB			8.5	
	G≥15dB	dB			11.5	
Gain Stability		dB			±0.10	
Settable tilt		dB	-2		+2	Positive tilt for G below 28dB
Gain Setting Accuracy		dB	-0.25		+0.25	
Gain Flatness vs. Wavelength		dB		± 0.5	± 0.6	
Overshoot/Undershoot for 16dB Add/Drop transient		dB			±1.5	
Stabilization Time after transient		μsec			500	
Transient Error Band		dB			0.5	
In/Out Return Loss (pumps on)		dB	40			
PDG + PDL		dB			0.3	
PMD		ps			0.3	
Power Measurement Accuracy		dB			± 0.5	

Optical Connectors

The EDFA is equipped with 3 Optical connections with fiber length of 100 +/- 5cm.

Connector	Type	Color	Description
Output	LC/UPC	White	Output optical port
Input	LC/UPC	Black	Input optical port
Monitor Output	LC/UPC	Blue	1% Output monitor

Electrical Specification

Parameter	Units	Specification			Notes
		Min.	Typ	Max.	
Supply voltage	V	4.75		5.25	
Power consumption	W			10	Over case temp range to EOL

Electronic Pin-out

Pin	Function	Pin	Function
1	5V	2	5V
3	N/C	4	N/C
5	Ground	6	Ground
7	Serial Input RS232 (LVTTL)	8	Serial Output RS232 (LVTTL)
9	Ground	10	Ground
11	N/C	12	RESET Input (Active Low)
13	Pump Disable (Active High)	14	Output Power Mute Input (Active High)
15	Case Temperature Alarm (Active High)	16	Common Alarm (Active High)
17	N/C	18	Pump Bias Alarm (Active High)
19	Loss of Input Alarm (Active High)	20	Loss of output alarm/Mute Alarm (Active High)
21	N/C	22	N/C
23	N/C	24	N/C
25	Ground	26	Ground
27	N/C	28	N/C
29	5V	30	5V

Control and Monitoring

Parameter	Specification
Communications	<ul style="list-style-type: none"> RS232 Command Protocol
Mode of Operation	<ul style="list-style-type: none"> Automatic Gain Control (Default startup mode) Automatic Power Control Manual pump power
Monitoring Functions	<ul style="list-style-type: none"> Output Power Monitoring Input Power Monitoring LD and PCB Temperatures

Block Diagram

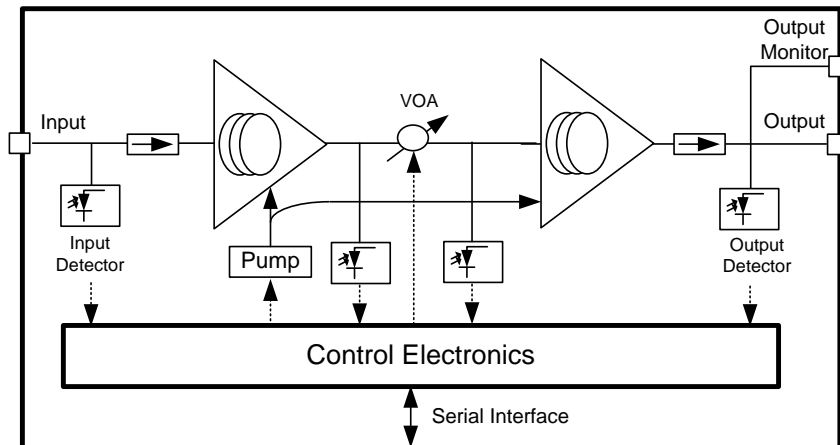

Mechanical Drawing

The following drawing shows the EDFA's width, height and length dimensions.

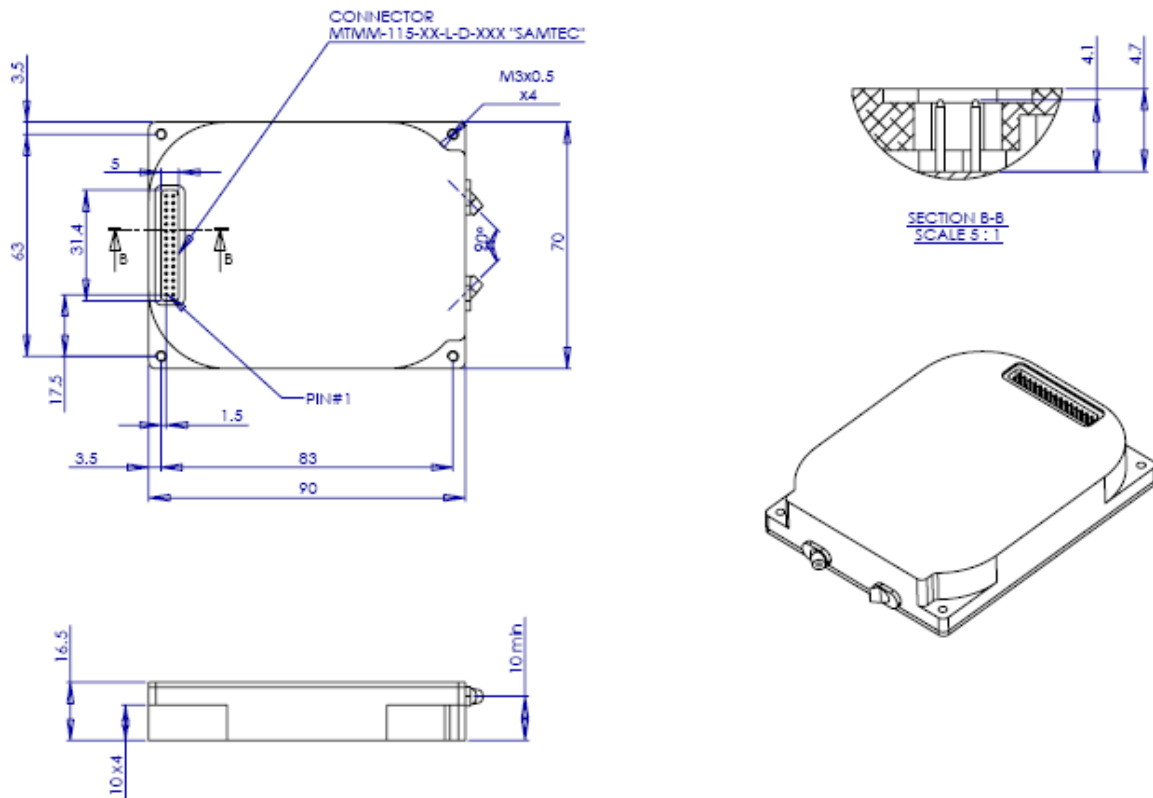

Environmental and Qualification

Parameter	Value/Range
Operating Case Temperature	0°C to +70 °C
Operating Humidity	5 to 85%
Storage Temperature	-40°C to +85°C
Storage Humidity	5 to 95%
Qualification	Telecordia GR1312
Laser Safety	Class 1M*

* Class 1M products are not hazardous under normal circumstances, but may pose an eye hazard when the laser output is viewed with certain optical instruments (for example eye loupes, magnifiers and microscopes) within a distance of 100 mm

Ordering Information:



800 Village Walk #316
Guilford, CT 06437
Ph: 203-401-8093

Email orders to: sales@xsoptix.com
Fax orders to: 800-878-7282