

PMux Polarization maintaining Multiplexer



Features

- ✓ 19" rack mountable rugged design
- ✓ Flexible Grid application possible
- ✓ Autonomous operation
 - ✓ just plug in power
- ✓ Windows based GUI allows status control
 - ✓ USB connection
- ✓ Seamless integration with *CoBrite_{MX}* tunable laser chassis

Applications

- ✓ generation of channel grids for DWDM transport testing

PMux is a polarization maintaining Multiplexer that complements our *CoBrite_{MX}* tunable laser series.

Stable output polarization of all sources allows for modulation of a channel comb using Mach-Zehnder structures to emulate DWDM spectra.

High channel counts, fixed grid

If your application requires ultra-high channel counts and low insertion loss budgeted our AWG based multiplexer is the ideal choice. It operates fully autonomous, status info can be retrieved via USB interface.

Low to medium channel counts, flexible grid

If a lower channel count is required or a flexible grid structure is needed, PM couplers can be integrated to match your needs. Using couplers instead of complicated tunable Filters or WSS structures to generate flexible grid scenarios offers cost savings and no effort for configuration of WSS structures while polarization preservation is delivered for free.

Hybrid designs

Both AWG & coupler can be combined in one device to blend advantages of each technology into a single system.

Optical Performance of AWG based *PMUX*

Optical Parameter	Specification			Unit
	Min	Typ.	Max	
Channel spacing		50 or 100		GHz
Insertion loss			6.0	dB
Uniformity across band		1	1.5	dB
Polarization Extinction Ratio	16	20		dB
Number of channels		Customer specified		
Channel Range		Customer specified		
Channel center offset	-0.04		+0.04	nm
3dB Pass band		0.55 (100GHz type)		nm
Input Connector		FC/APC, FC/PC, SC/PC		
Output Connector		FC/APC, FC/PC, SC/PC		
Optical Fiber		Polarization- maintaining PANDA type Fiber		

Operating Conditions & Mechanical Parameter

Operating Temperature	0 to 50°C, non-condensing
Storage Temperature	-20°C to 70°C, non-condensing
Size of device (H x W x D)	100 x 460 x 540mm 4 x 19 x 21 inch
Power Supply	100-240 VAC, 2A, 50/60Hz

Ordering Information:



800 Village Walk #316
Guilford, CT 06437
Ph: 203-401-8093

Email orders to: sales@xsoptix.com
Fax orders to: 800-878-7282

Application example

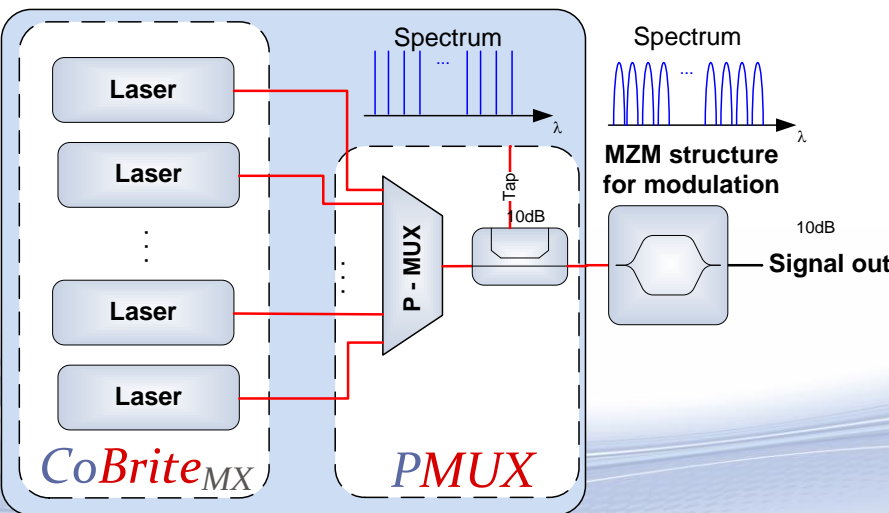

Contact information

ID Photonics GmbH
Anton-Bruckner-Str. 6
85579 Neubiberg
GERMANY
Tel.: + 49 (0) 89 – 201 899 16

info@id-photonics.com
www.id-photonics.com