

1 – Description.....	p1
2 – Block diagrams.....	p2
3 – Absolute maximum ratings.....	p3
4 – Operating conditions.....	p3
5 – MINT specifications.....	p4
6 – MINT statistic data.....	p6
7 – WT-MINT specifications.....	p7
8 – Phase tuning options.....	p9
9 – ER attenuation option.....	p11
10 – IL attenuation option.....	p13
11 – Tunable coupling option.....	p13
12 – TAP option.....	p15
13 – Second input option.....	p15
14 – Wavelength range.....	p15
15 – Fiber type and connectors.....	p16
16 – Custom products.....	p16
17 – Packages layout.....	p16
18 – Revision.....	p17

## 1 – Description

The Micro Interferometer (MINT) is a Delay Line Interferometer (DLI) that performs the interference between an incoming signal and itself delayed by one bit-time. Dedicated to D(Q)PSK demodulation it can be used in many other applications. MINT is tunable to enable a precise matching of the carrier frequency. Two phase tuning options are available: the ultra-fast option (U), which exhibits very low tuning time constant (20 $\mu$ s), and the low voltage option (L), which needs only 3V to reach the tuning range.

The WT-MINT is a Widely Tunable MINT that enables to set the delay of the interferometer to the desired value. This can be done either with a micrometer head (manual option) or with a motorized translation stage (piloted version). In both case U and L option are available to precisely match the carrier frequency. There are three ranges of WT-MINT:

- WT-MINT 100ps: it enables to set an optical delay range of 100ps (corresponding to a Free Spectral Range of 10GHz to infinite, or – for instance – 5GHz to 10GHz). Available with manual or piloted option.
- WT-MINT 300ps: it enables to set an optical delay range of 300ps (corresponding to a Free Spectral Range of 3.3GHz to infinite, or 2.5GHz to 10GHz). Available with manual or piloted option.
- WT-MINT 3000ps: it enables to set an optical delay range of 3000ps (corresponding to a Free Spectral Range of 0.33GHz to infinite). Available with piloted option only.

MINT and WT-MINT products are also available with PM fibers.



MINT packaging



WT-MINT packaging

## 2 – Block diagrams

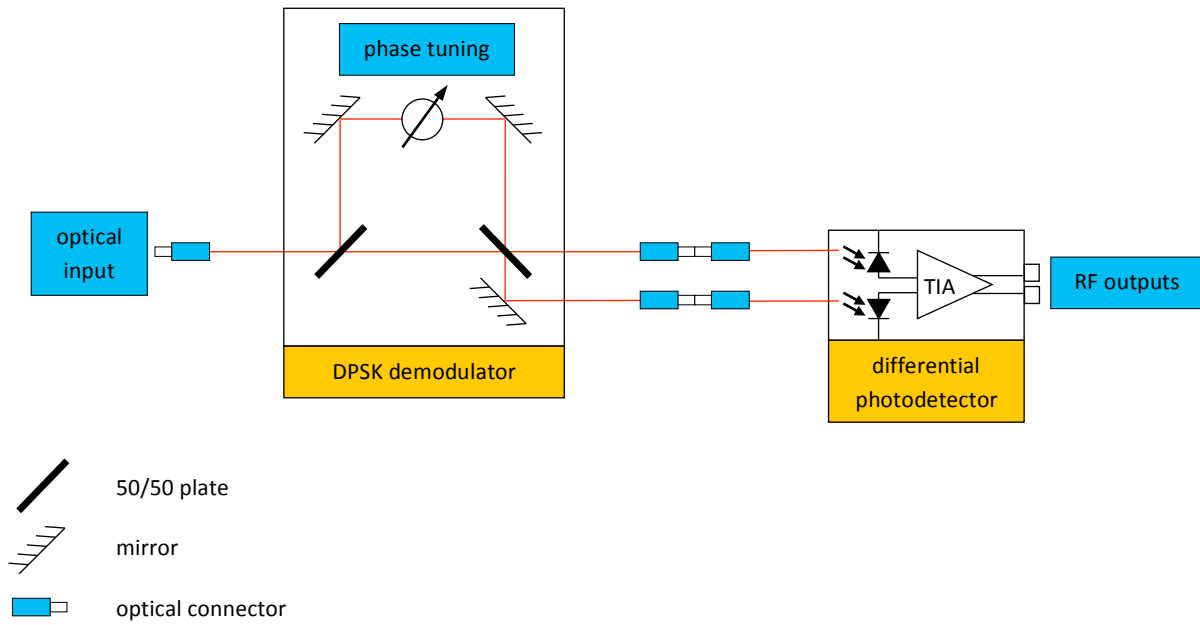

Block diagram: MINT

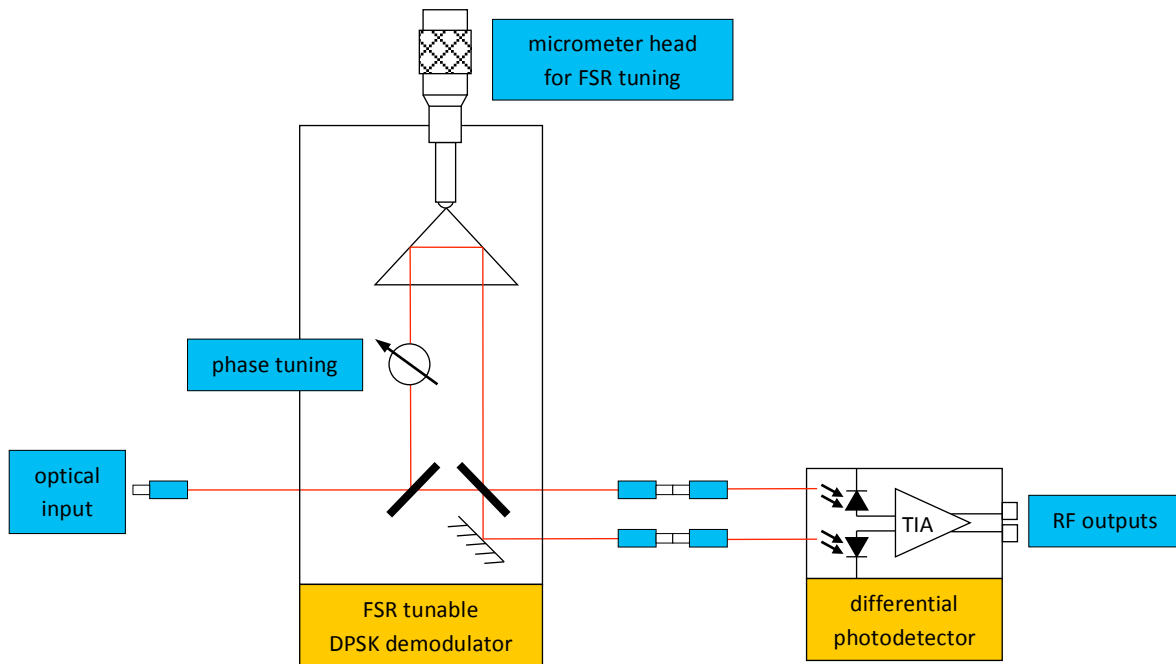

Block diagram: WT-MINT

The incoming signal is split in two parts. One is delayed regarding the other and then both are recombined on two outputs where they interfere one with each other. Both outputs are phase shifted by 180° and thus can be plugged to balanced or differential photodiodes that will convert a phase modulation into an amplitude modulation.

The delay between both arms of the interferometer should be equal to the time-bit ( $T_{bit}$ ) of the incoming signal. Then the interferometer is characterized by its Free Spectral Range (FSR) which is linked to  $T_{bit}$  by the relation  $FSR=1/T_{bit}$ .

### 3 – Absolute maximum ratings

Parameter	Symbol	Min	Typ.	Max	Unit	Remarks/Conditions
Maximal optical input power	OpIn			300	mW	
Storage temperature range	MINT	STR	-40	80	°C	
	WT-MINT		-10	40		
Humidity	RH	5		85	%	Non condensing
Fiber bend radius		20			mm	
Maximum input voltage	U option	$V_{max}$		100	V	
	L option			4		

### 4 – Operating conditions

Parameter	Symbol	Min	Typ.	Max	Unit	Remarks/Conditions
Operating wavelength	OWR	1520		1570	nm	
Operating temperature range	MINT	OTR	0	70	°C	
	WT-MINT		10	35		

## 5 – MINT specifications

MINT, FSR > 0.4GHz							
Parameter		Symbol	Min	Typ.	Max	Unit	Remarks/Conditions
Free Spectral Range <sup>1</sup>		FSR	0.4			GHz	Any FSR > 0.4GHz can be provided
FSR accuracy <sup>1</sup>	FSR>2.5GHz	ΔFSR			1	%FSR	
	FSR<2.5GHz				2		
Insertion Losses <sup>1</sup>		IL			2.0	dB	
IL uniformity <sup>1</sup>		ΔIL			0.5	dB	
Polarization Dependant Losses <sup>1,2</sup>	FSR>2.5GHz	PDL			0.3	dB	
	FSR<2.5GHz				0.5		
Polarization Dependant Frequency Shift <sup>1,2</sup>	FSR>10GHz	PDFS			2	%FSR	
	FSR<10GHz				4		
Extinction Ratio <sup>1</sup>	FSR>2.5GHz	ER	18			dB	
	FSR<2.5GHz		15				
Polarization Extinction Ratio <sup>1,3</sup>		PER	20	25		dB	
Tuning range					1.5	FSR	
Tuning voltage	L	V			3	V	Voltage needed to reach the tuning range
	U			75	90		
Tuning time constant	L	τ			1.0	s	To reach 50% of the final state
	U				0.02		
Power consumption	L	P			0.5	W	
	U				0.001		
Polarization Mode Dispersion		PMD			0.1	ps	
Chromatic Dispersion		CD			1	ps/nm	
Optical Return Loss		ORL	35			dB	
Skew				0.5	1.0	ps	
Packaging size <sup>4</sup>	FSR > 20GHz		44 x 26 x 9.5			mm <sup>3</sup>	
	2.5 <FSR < 20GHz or PM fiber FSR > 20GHz		100 x 55 x 16				
	FSR<2.5GHz		130 x 65 x 19.5				
Phase tuning connector	FSR>2.5GHz		0.1 inch PIN header				
	FSR<2.5GHz		BNC				
Fiber Pigtail Type	SM		SMF-28				With 900μm loose tube
	PM		PANDA PM				
Fiber Pigtail Length			0.9	1.0	1.1	m	

<sup>1</sup> measured over OTR and OWR for all states of polarization

<sup>2</sup> for Single Mode MINT

<sup>3</sup> for Polarization Maintaining MINT

<sup>4</sup> excluding fiber boot

## 6 – WT-MINT specifications

The 100ps WT-MINT allows a tunable FSR from 10GHz to infinite. A tunable FSR from 5GHz to 10GHz, or others FSR ranges are also available. Please contact us.

WT-MINT, 100ps Optical Delay Range							
Parameter		Symbol	Min	Typ.	Max	Unit	Remarks/Conditions
Optical Delay Range		ODR	100			ps	
Manual WT-MINT ODR sensitivity					8	fs	
Motorized WT-MINT	Minimum incremental motion				2	fs	
	Relative accuracy				75	fs	
	Unidirectional repeatability				15	fs	
	Bidirectional repeatability				20	fs	
Insertion Losses <sup>1</sup>		IL			2.5	dB	
IL uniformity <sup>1</sup>		$\Delta$ IL			0.5	dB	
Polarization Dependant Losses <sup>1,2</sup>		PDL			0.5	dB	
Polarization Dependant Frequency Shift <sup>1,2</sup>		PDFS			3.0	%FSR	
Extinction Ratio <sup>1</sup>		ER	18			dB	
Polarization Extinction Ratio <sup>1,3</sup>		PER	20	25		dB	
Tuning range					1.5	FSR	
Tuning voltage	L	V			3	V	Voltage needed to reach the tuning range
	U			75	90		
Tuning time constant	L	$\tau$			1.0	s	To reach 50% of the final state
	U				0.02		
Power consumption	L	P			0.5	W	
	U				0.001		
Polarization Mode Dispersion		PMD			0.1	ps	
Chromatic Dispersion		CD			1	ps/nm	
Optical Return Loss		ORL	35			dB	
Skew				0.5	1.0	ps	
Packaging size <sup>4</sup>			216 x 92 x 40			mm <sup>3</sup>	
Phase tuning connector			BNC				
Fiber Pigtail Type	SM		SMF-28				With 900 $\mu$ m loose tube
	PM		PANDA PM				

<sup>1</sup> measured over ODR, OTR and OWR for all states of polarization

<sup>2</sup> for Single Mode WT-MINT

<sup>3</sup> for Polarization Maintaining WT-MINT

<sup>4</sup> excluding micrometer head or piloted actuator

The 300ps WT-MINT allows a tunable FSR from 3.3GHz to infinite. For instance, a tunable FSR from 2.5GHz to 10GHz, or others FSR ranges are also available. Please contact us.

WT-MINT, 300ps Optical Delay Range						
Parameter	Symbol	Min	Typ.	Max	Unit	Remarks/Conditions
Optical Delay Range	ODR	300			ps	
Manual WT-MINT ODR sensitivity				15	fs	
Motorized WT-MINT	Minimum incremental motion			3	fs	
	Relative accuracy			150	fs	
	Unidirectional repeatability			30	fs	
	Bidirectional repeatability			40	fs	
Insertion Losses <sup>1</sup>	IL			4.0	dB	
IL uniformity <sup>1</sup>	ΔIL			1.0	dB	
Polarization Dependant Losses <sup>1,2</sup>	PDL			0.8	dB	
Polarization Dependant Frequency Shift <sup>1,2</sup>	PDFS			5.0	%FSR	
Extinction Ratio <sup>1</sup>	ER	15			dB	
Polarization Extinction Ratio <sup>1,3</sup>	PER	20	25		dB	
Tuning range				1.5	FSR	
Tuning voltage	L	V		3	V	Voltage needed to reach the tuning range
	U		75	90		
Tuning time constant	L	τ		1.0	s	To reach 50% of the final state
	U			0.02	ms	
Power consumption	L	P		0.5	W	
	U			0.001		
Polarization Mode Dispersion	PMD			0.1	ps	
Chromatic Dispersion	CD			1	ps/nm	
Optical Return Loss	ORL	35			dB	
Skew			0.5	1.0	ps	
Packaging size <sup>4</sup>		216 x 92 x 40			mm <sup>3</sup>	
Phase tuning connector		BNC				
Fiber Pigtail Type	SM	SMF-28			With 900μm loose tube	
	PM	PANDA PM				

<sup>1</sup> measured over ODR, OTR and OWR for all states of polarization

<sup>2</sup> for Single Mode WT-MINT

<sup>3</sup> for Polarization Maintaining WT-MINT

<sup>4</sup> excluding micrometer head or piloted actuator

The 3ns WT-MINT allows a tunable FSR from 0.33GHz to infinite.  
 The 12ns WT-MINT allows a tunable FSR from 83MHz to infinite.

WT-MINT, 3ns to 12ns Optical Delay Range							
Parameter		Symbol	Min	Typ.	Max	Unit	Remarks/Conditions
Optical Delay Range		ODR	3000			ps	
Minimum incremental motion	3ns delay				10	fs	
	12ns delay				40		
Relative accuracy	3ns delay				250	fs	
	12ns delay				1000		
Unidirectional repeatability	3ns delay				30	fs	
	12ns delay				120		
Bidirectional repeatability	3ns delay				150	fs	
	12ns delay				600		
Insertion Losses <sup>1</sup>		IL			4.0	dB	
IL uniformity <sup>1</sup>		$\Delta$ IL			1.0	dB	
Polarization Dependant Losses <sup>1,2</sup>		PDL			0.8	dB	
Polarization Dependant Frequency Shift <sup>1,2</sup>		PDFS			5.0	%FSR	
Extinction Ratio <sup>1</sup>		ER	15			dB	
Polarization Extinction Ratio <sup>1,2</sup>		PER	20	25		dB	
Tuning range					1.5	FSR	
Tuning voltage	L	V		75	3	V	Voltage needed to reach the tuning range
	U				90		
Tuning time constant	L	$\tau$			1.0	s	To reach 50% of the final state
	U				0.02		
Power consumption	L	P			0.5	W	
	U				0.001		
Polarization Mode Dispersion		PMD			0.1	ps	
Chromatic Dispersion		CD			1	ps/nm	
Optical Return Loss		ORL	35			dB	
Skew				0.5	1.0	ps	
Packaging size			750 x 400 x 129				
Phase tuning connector			BNC				
Fiber Pigtail Type	SM		SMF-28				With 900 $\mu$ m loose tube
	PM		PANDA PM				

<sup>1</sup> measured over ODR, OTR and OWR for all states of polarization

<sup>2</sup> for Polarization Maintaining WT-MINT

## 7 – Phase tuning options

For DPSK demodulation, the phase tuning is essential in order to control the contrast between both outputs of the interferometer/demodulator.

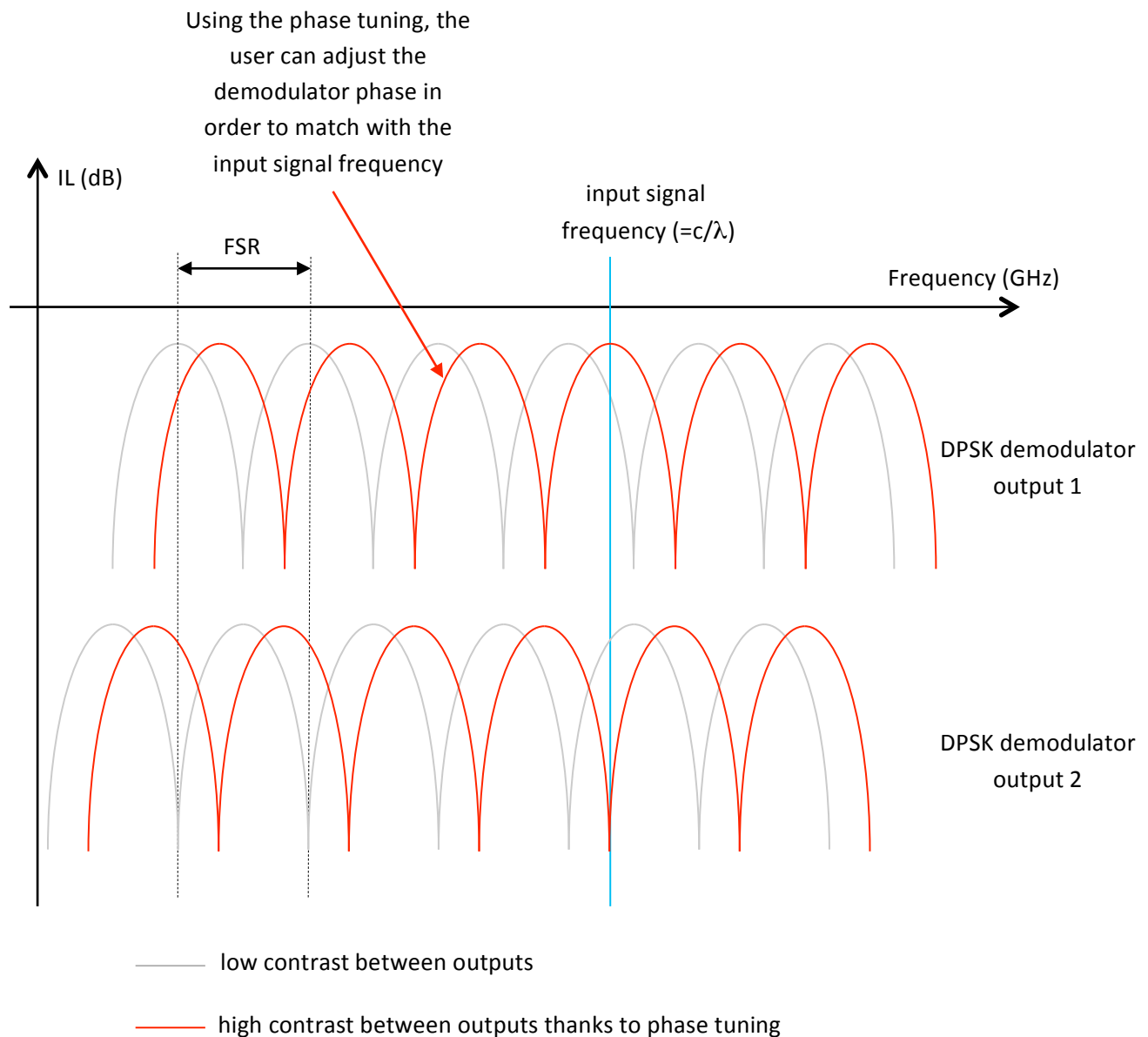

The FSR variation is not significant (and can be considered as invariant) when the user adjust the phase of the demodulator/interferometer.

KYLIA proposes for all its DPSK demodulators (MINT and WT-MINT) two different phase tuning options:

**U option:** Ultra-fast response based on a piezo actuator.

This option is helpful for fast shifting systems (instability of the laser for instance). The DLI can adapt itself instantaneously to the environment, if a closed loop between BER and phase shifting is set up. This solution is mainly used in labs.



With this option, the user can accomplish a shift of one FSR by applying a 60V voltage. The tuning time is better than 20 $\mu$ s.

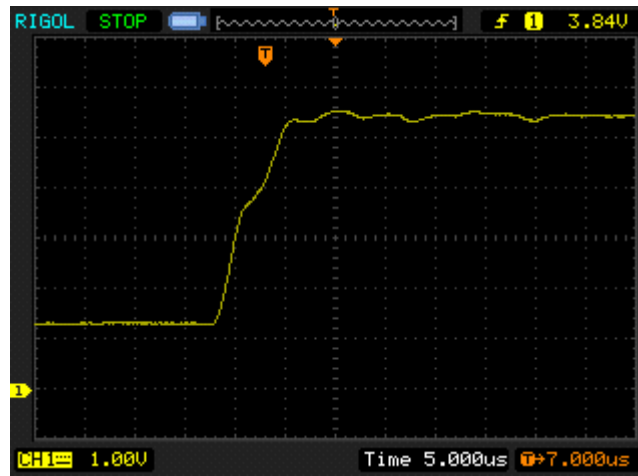

*Tuning speed for a U option DPSK demodulator*

**L option:** Low-voltage tuning based on a resistive heater

Phase shift is obtained using a resistive heater fixed on an optical element. Changing the voltage changes the local temperature and thus the optical index, then the optical delay.

With this option, the user can accomplish a shift of one FSR by applying a 2V voltage. The tuning time is better than 1s.

### 8 – ER attenuation option

It is possible to tune the extinction ratio of an interferometer by adjusting the power in both arms. When the power is the same the ER will be the greatest. By attenuating the power in one arm, ER will be reduced.

The ER attenuation option for MINT and WT-MINT consist of a micrometer head that can adjust the power of one arm of the interferometer. It enables to tune the ER down to 0dB (one arm is totally shut down) with an accuracy of 1dB.

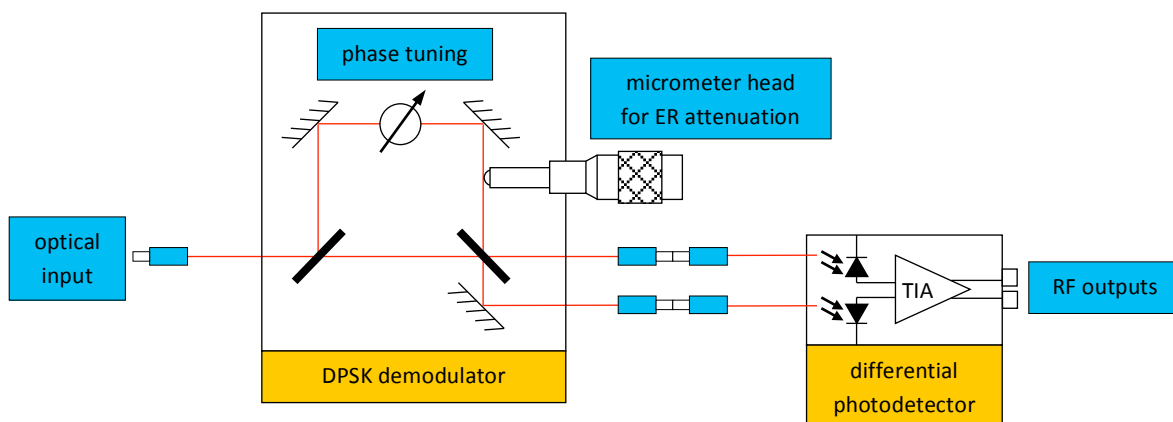

*Block diagram: DLI with ER attenuation option*

On the following graph, we show the variation of the spectral response of our DLI by attenuating the optical beam for one arm of the interferometer.

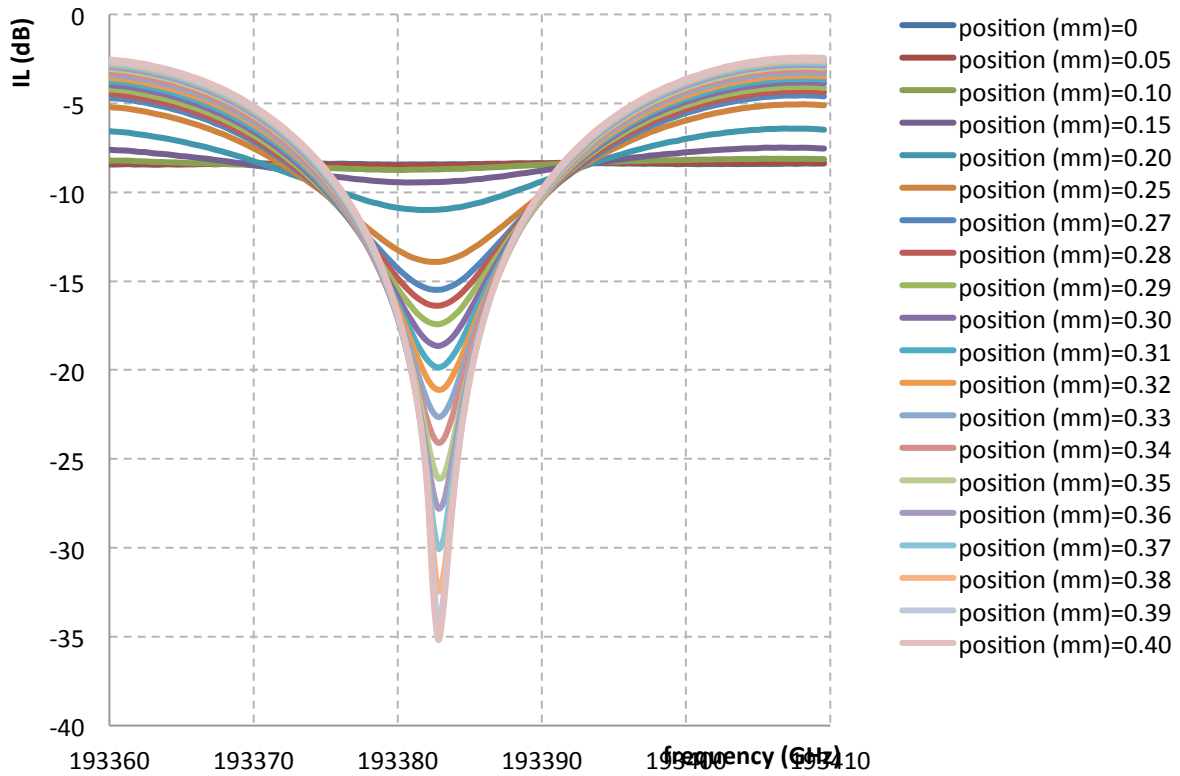

MINT spectral response with ER attenuation

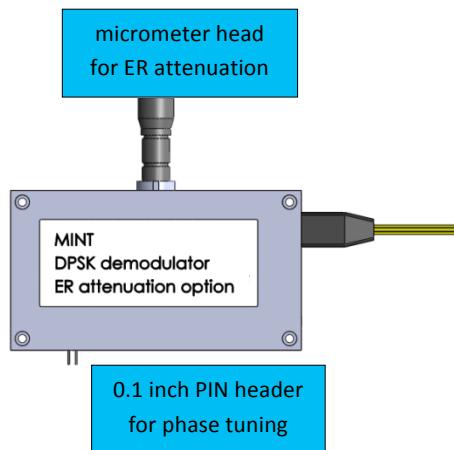

MINT with ER attenuation option

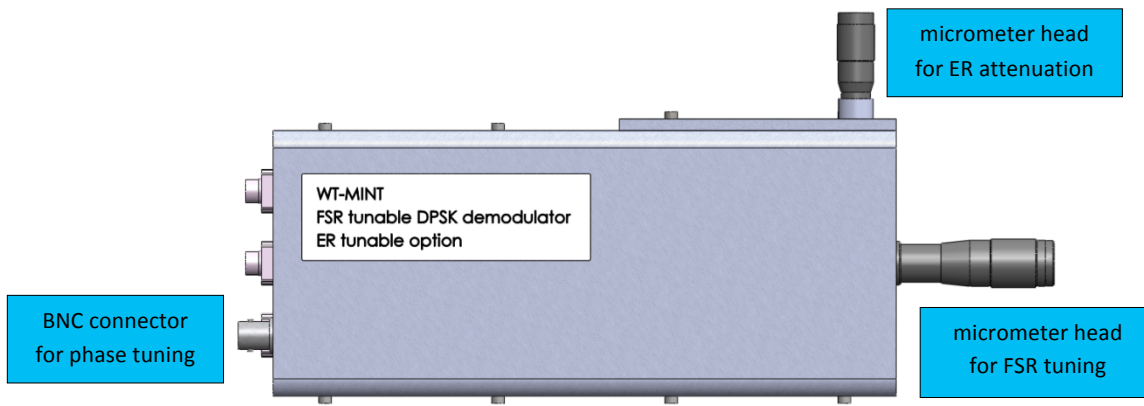

WT-MINT with ER attenuation option

### 9 – IL attenuation option

IL attenuation enables to increase the IL on each output individually. This can be done thanks to a micrometer head. The attenuation can be total (no power exits from the output) and adjusted with an accuracy of 0.1dB.

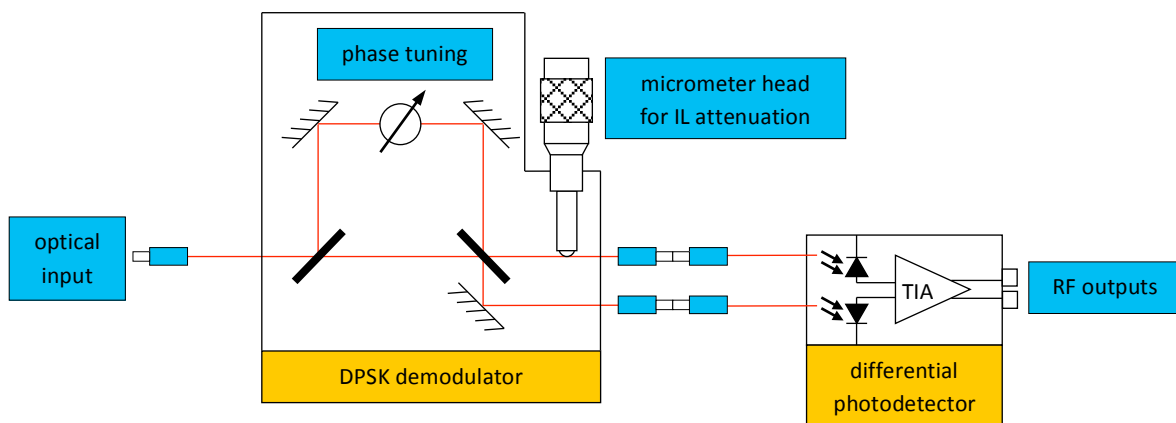

Block diagram: DLI with IL attenuation option

### 10 – Tunable coupling option

This option is available for PM MINT or PM WT-MINT only. It enables to adjust the splitting ratio of the interferometer (which is 50/50 for standard interferometers) from 100/0 to 0/100. This can be very useful if a precise 50/50 ratio is needed.

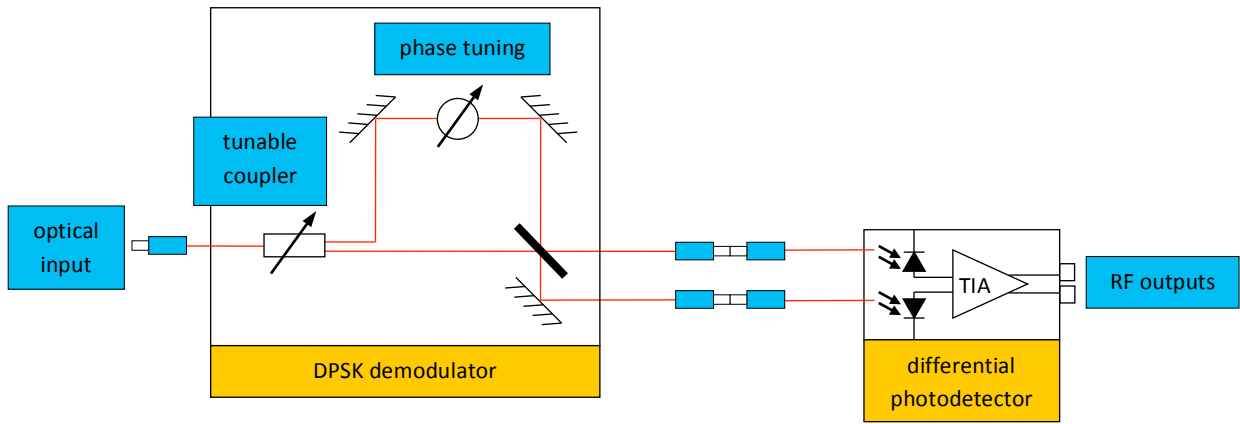

Block diagram: DLI with tunable coupling option

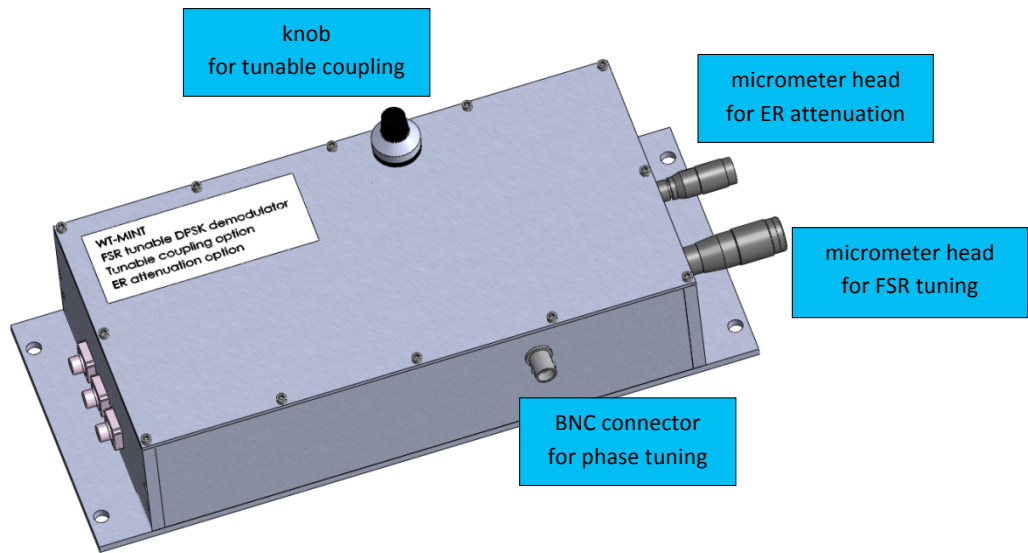

WT-MINT PM with tunable coupling and ER attenuation options

### 11 – TAP option

Thanks to the flexibility of our technology, we can propose to add optical TAP outputs in our products. The TAP ratio can be 4% or 50%.

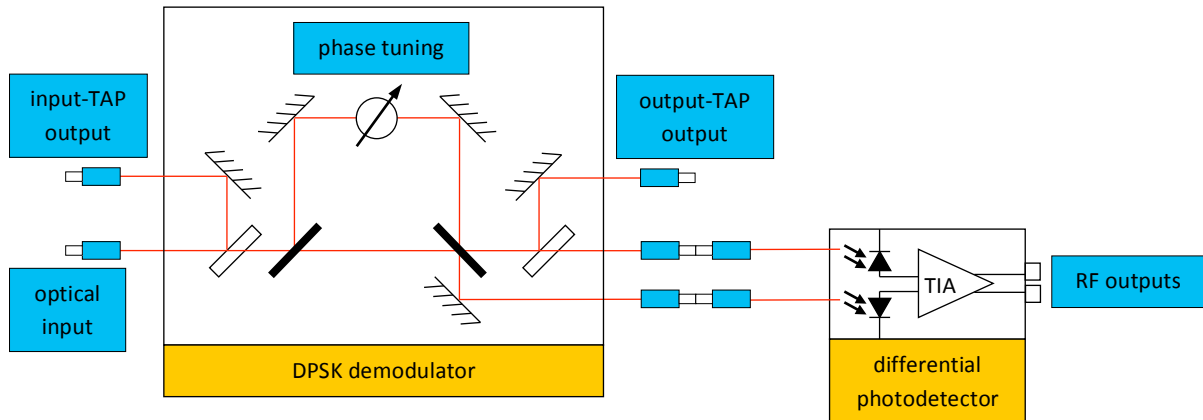

Block diagram: MINT with TAP option for input and output signals

### 12 – Second input option

A second input can also be added in our product.

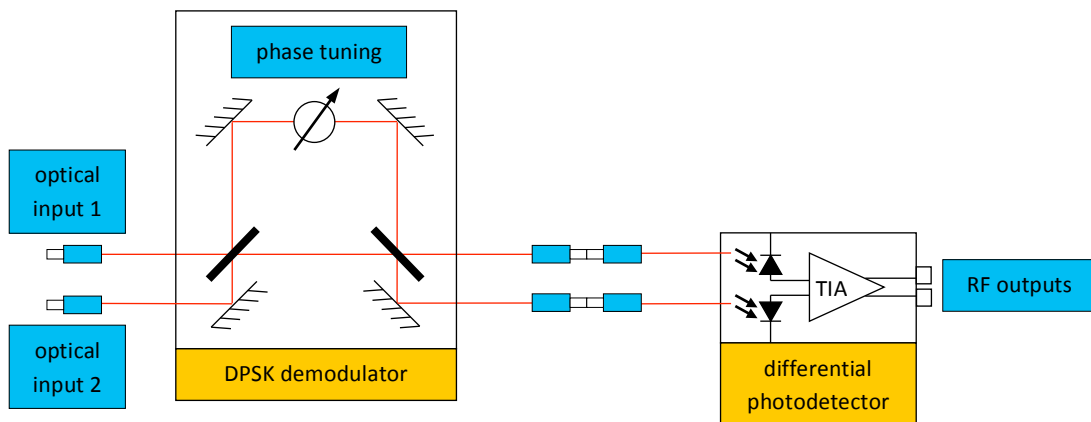

Block diagram: MINT with a second optical input

### 13 – Wavelength range

MINT and WT-MINT can be proposed at different wavelength range, from the visible to the IR (800nm, 1064nm, 1300nm...). The device will be operational on a wavelength range of a tens of nanometers centered on the wavelength required by customer.

## 14 – Fiber type and connectors

Every MINT or WT-MINT can be proposed either with SM or PM fibers.

The devices can be proposed with any kind of connectors (FP/UPC, FC/APC, SC/PC, SC/APC, LC/PC, E2000/PC, E2000/APC, etc...).

## 15 – Custom products

Thanks to our free-space technology we can easily customize most of our products and so it is for the MINT and WT-MINT. Customer can feel free to ask for any customization they need. We will examine the request and do our best to have a positive answer.

## 16 – Packages layout

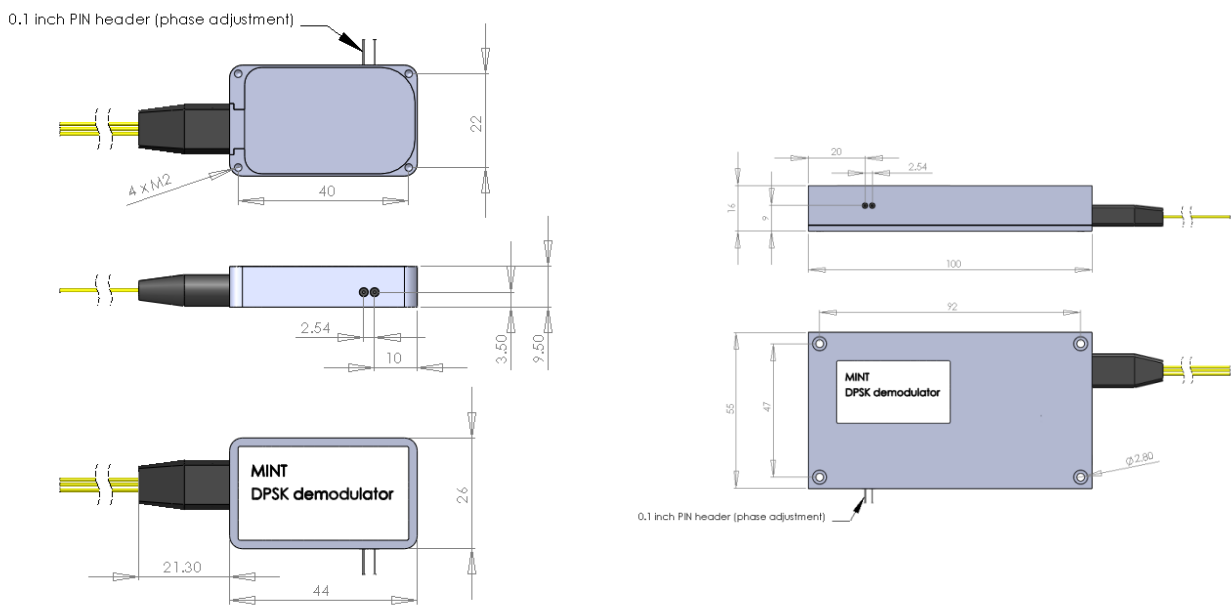

MINT packaging : FSR > 20GHz

MINT packaging : FSR > 2.5GHz

### Ordering Information:



800 Village Walk #316  
 Guilford, CT 06437  
 Ph: 203-401-8093

Email orders to: [sales@xsoptix.com](mailto:sales@xsoptix.com)  
 Fax orders to: 800-878-7282

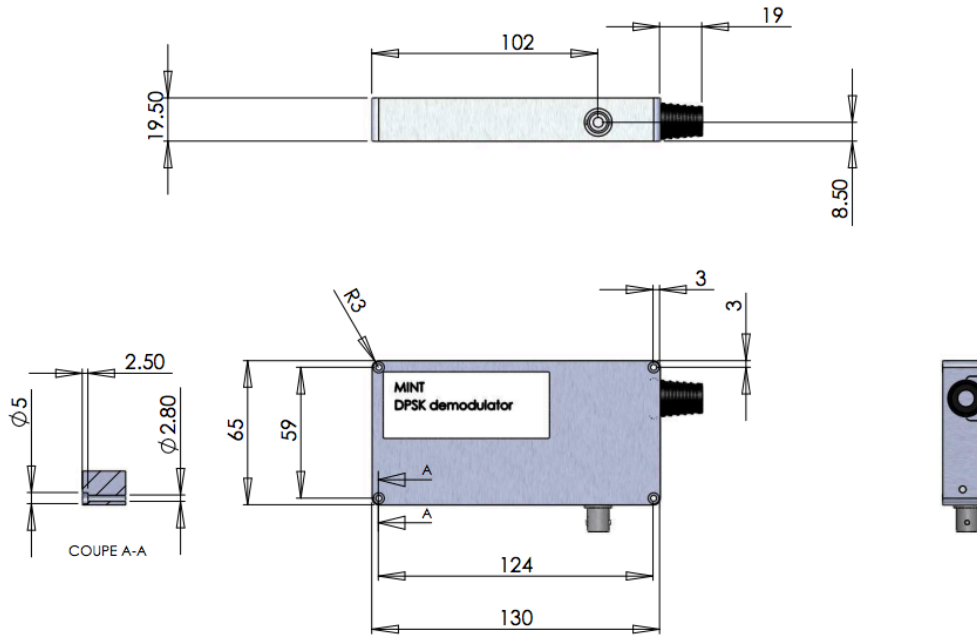

MINT packaging : FSR < 2.5GHz

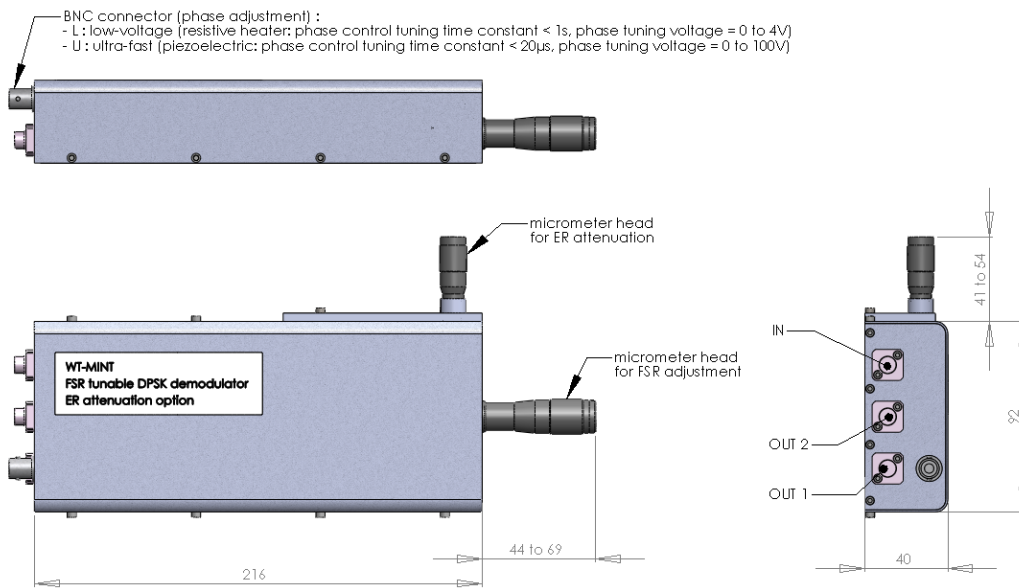

WT-MINT packaging (with ER attenuation option)

17 – Revision

date	version	Object
March 21, 2013	MINT V1.0	Creation
May 15, 2014	MINT V1.1	Phase tuning option explanation MINT packaging for FSR < 2.5GHz
February 3 <sup>rd</sup> , 2015	MINT V1.2	Added 12ns delay WTMINT
January 22 <sup>nd</sup> , 2016	MINT V1.3	Specifications update