

30 GHz HIGH GAIN PHOTORECEIVER

XPRV2325A

The XPRV2325A photoreceiver is a single-ended front-end with a bandwidth of 30 GHz supporting both optical windows, O-band, and C-band. The module contains a waveguide-integrated PIN-photodiode and a limiting transimpedance amplifier that can optionally be controlled via an I²C interface. The amplifier has a typical bandwidth of 31 GHz, is optimized for linearity and for low noise and exhibits a manual (MGC) as well as an automatic gain control (AGC) mode. Depending on the settings, the conversion gain can be varied from 25 to 1800 V/W (MGC mode) or the output amplitude can be varied from 0 to 300 mV peak-peak (AGC mode). An integrated feedback loop optimizes the performance in the frequency and/or time domain with respect to different optical input power. Incorporated blocking capacitors enable AC output coupling.

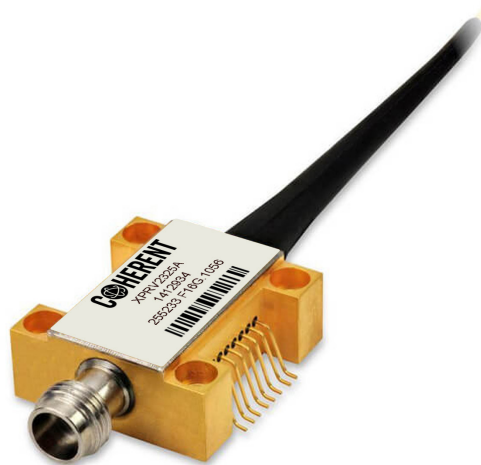

Picture shows product example, actual product might differ

FEATURES

- Linear PIN/TIA photoreceiver module
- 31 GHz typical bandwidth
- Mode Select and optional I2C interface
- Adjustable conversion gain/output swing
- RF output disable
- AC coupled output
- 1310 and 1550 nm wavelength

APPLICATIONS

- Laboratory test equipment
- Analog Photonic links
- Radio-over-Fiber

Ordering Information:



800 Village Walk #316
Guilford, CT 06437
Ph: 203-401-8093

Email orders to: sales@xsoptix.com
Fax orders to: 800-878-7282



30 GHz HIGH GAIN PHOTORECEIVER

Product Selection

XPRV2325A -Vy-zz

Vy	VF	= Female V [®] connector
zz	FP	= FC/PC connector (standard)
	FA	= FC/APC connector
		Other customized configurations on request

Block Diagram

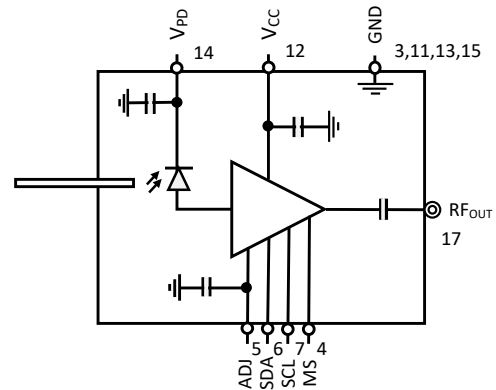

Key Specifications

Parameter	Symbol	Condition	Min.	Typ.	Max.	Unit
Operating Case Temperature	T_{CASE}		0		75	°C
Storage Temperature	T_{STORE}		-40		85	°C
Wavelength Range	λ	O-band C-band		1310 1550		nm
Photodiode Supply Voltage	V_{PD}			3.3		V
Average Optical Input Power	P_{OPT_avg}				3	dBm
Photodiode DC Responsivity	R	Optimum polarization	0.4			A/W
3 dB Cut-off Frequency	f_{3dB}	MGC mode, 100D		31		GHz
Output Reflection Coefficient	s_{22}				-5	dB
Output Voltage Swing	V_{OUT}	Maximum gain			350	mV
Power Consumption	P_{CON}	$V_{CC} = \text{max}$		0.18		W

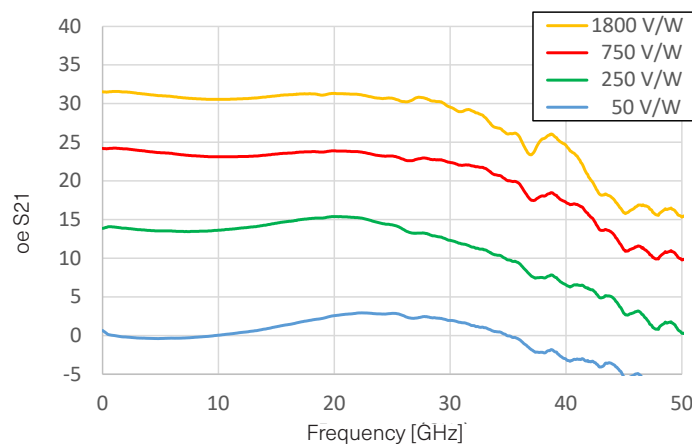

Typical frequency response s21