

POLARISATION SWITCH

PSW-LN-0.1

Low frequencies Polarization Switch

The PSW-LN-0.1 Polarization Switch is an integrated optics waveguide device that switches the polarization state of an input light between two linear orthogonal output states at frequencies up to 200 MHz.

The PSW-LN-0.1 Polarization Switch is based on a birefringent LiNbO₃ phase modulator whose waveguide is illuminated at 45° of its main axis. The input state of polarization (SOP) is thus split up in two orthogonal TE and TM polarization states. When a RF modulation signal is applied via the control electrodes, an optical path difference between the TE and TM components is produced, resulting in a new state of polarization (SOP) for the output light.

The PSW-LN Polarization Switch acts as a waveplate with user adjustable delay. When a modulation signal with properly selected peak levels is applied to the modulator, the input linear polarized light is exiting either in an unchanged direction, or rotated by 90°. The two directions are matched with the main axis of the optical output PM fiber and the PSW-LN thus operates as a slow/fast axis switch. Ultimately, the phase modulation signal can be adjusted to provide a highly linear SOP on either axis of the output fiber. This polarization rotation provides an efficient solution for high speed Polarization Switching.



Features

- Low insertion loss
- Very low switching voltage
- Low differential group delay
- Compact design

Applications

- Polarization shift keying (PSK)
- High-speed test equipment

Options

- 1300 nm band versions
- Choice of optical connectors

Related Equipments

- Exail RF amplifiers

PSW-LN-0.1 Performance Highlights

Parameter	Min	Typ	Max	Unit
Operating wavelength	1530	-	1580	nm
Insertion loss	-	3.5	4	dB
Electro-optical bandwidth	150	200	-	MHz
Switching voltage @50kHz	-	6	7	V

Specifications given at 25 °C, 1550 nm

Ordering Information:



800 Village Walk #316
Guilford, CT 06437
Ph: 203-401-8093

Email orders to: sales@xsoptix.com
Fax orders to: 800-878-7282

PSW-LN-0.1

200 MHz Polarization Switch

Electrical Characteristics

Parameter	Symbol	Condition	Min	Typ	Max	Unit
Electro-optical bandwidth	S_{21}	RF electrodes	150	200	-	MHz
Switching voltage @50 kHz	$V_{50 \text{ kHz}}$	RF electrodes	-	6	7	V
Switching voltage @150 MHz	$V_{150 \text{ MHz}}$	RF electrodes	-	8	9	V
RF input impedance	Z_{in-RF}	-	-	10 000	-	Ω

Optical Characteristics

Parameter	Symbol	Condition	Min	Typ	Max	Unit
Crystal	-	-	Lithium Niobate X-Cut Y-Prop			
Operating wavelength	λ	-	1530	1550	1580	nm
Insertion loss	IL	Without optical connectors*	-	3.5	4	dB
Polarization dependent loss	PDL	-	-	-	1	dB
Polarization extinction ratio	PER	-	18	20	-	dB
Optical return loss	ORL	-	-40	-45	-	dB

Absolute Maximum Ratings

Stresses in excess of the absolute maximum ratings can cause permanent damage to the device. These are absolute stress ratings only. Functional operation of the device is not implied at these or any other conditions in excess of those given in the operational sections of the data sheet. Exposure to absolute maximum ratings for extended periods can adversely affect device reliability.

Parameter	Symbol	Min	Max	Unit
Modulation voltage range	EV_{in}	-20	+20	V
Optical input power	OP_{in}	-	20	dBm
Operating temperature	OT	0	+70	°C
Storage temperature	ST	-40	+85	°C

POLARIZATION SWITCH | PSW-LN-0.1 | 3/3

Mechanical Diagram and Pinout

All measurements in mm

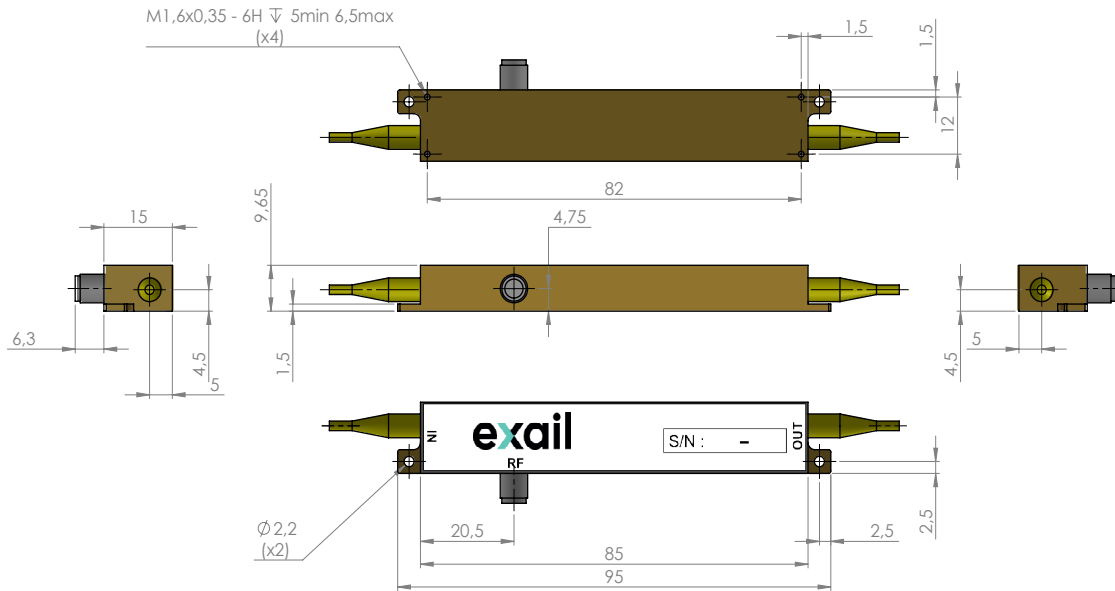

Port	Function	Note
IN	Optical input port	Polarization maintaining 1550 nm Corning PM 15-U25D Length: 1.5 meter, buffer diameter: 900 µm
OUT	Optical output port	Polarization maintaining 1550 nm Corning PM 15-U25D Length: 1.5 meter, buffer diameter: 900 µm
RF	RF input port	Female K (SMA compatible)

Ordering information

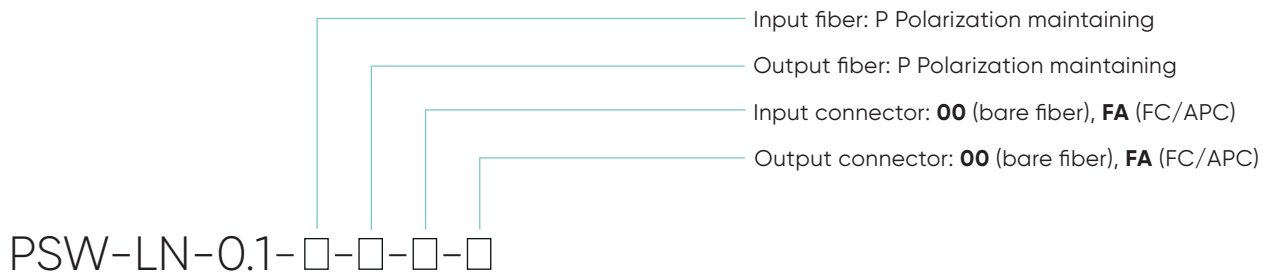

About us

Exail Photonics produces specialty optical fibers and Bragg gratings based fiber optics components and provides optical modulation solutions based on the company lithium niobate (LiNbO₃) modulators and RF electronic modules. Exail Photonics serves a wide range of industries: sensing and instruments, defense, telecommunications, space and fiber lasers as well as research laboratories all over the world.

Exail reserves the right to change, at any time and without notice, the specifications, design, function or form of its products described herein. All statements, specification, technical information related to the products herein are given in good faith and based upon information believed to be reliable and accurate at the moment of printing. **However, Exail provides no warranty (whether express or implied or statutory) as to the description, sufficiency, accuracy or completeness, merchantability or fitness for a particular purpose of any information or specification detailed herein.** No liability is assumed for any inaccuracies and/or as a result of use of the products. The user must validate all parameters for each application before any use and he shall assume all risks and responsibilities in connection with the use of the products.