

DRIVER

DR-VE-10-MO

Versatile RF amplifier module

The DR-VE-10-MO is a high-grade OEM RF amplifier assembled with the latest generation of monolithic microwave integrated circuits (MMICs) chips. This confers to the device the highest performance we can expect from an RF amplifier: wide bandwidth for fast rise and fall time, high linearity, very good signal to noise ratio, and very low time jitter.

The DR-VE-10-MO is a non-inverting medium output voltage RF amplifier module. It is named VErSatile because it can be used for linear (analog, RFoF, PAM), low duty cycle pulses (square or pulse shaping, PPM) and digital modulation schemes (RZ & NRZ).

For each of these applications, the RF amplifier is factory preset with optimal setpoints for a convenient and ease of use operation. An embedded microcontroller allows the user to select the right operating mode through a Graphical User Interface. The GUI also comes with a custom tuning mode where the gain, amplitude and cross point can be optimized over a very wide tuning range.



Features

- Output voltage up to 8 V_{pp}
- Linear / pulse / digital amplifier
- Bandwidth from 16 kHz up to 15 GHz
- Preset modes

Applications

- RFoF, PAM, Analog modulation
- PPM, low duty-cycle pulse train
- Pulse carving and shaping
- Digital RZ, NRZ

Related Equipments

- Phase and intensity modulators

Performance Highlights

Parameter	Min	Typ	Max	Unit
Cut-off frequencies	16 k	-	15 G	Hz
Output voltage	-	-	8	V _{pp}
Gain	28	30	-	dB
Saturated power	-	-	23	dBm

Ordering Information:



800 Village Walk #316
Guilford, CT 06437
Ph: 203-401-8093

Email orders to: sales@xsoptix.com
Fax orders to: 800-878-7282

DR-VE-10-MO

Versatile RF amplifier module Driver

Characteristics and measurements

Parameter	Symbol	Conditions	Min	Typ	Max	Unit
Impedance	Z	-	-	50	-	Ω
Low frequency 3dB point	f_{lower}	-	-	16	25	kHz
High frequency 3dB point	f_{higher}	-	15	16	-	GHz
Small signal Gain	S_{21}	-	28	30	-	dB
Gain ripple	-	$f < 15 \text{ GHz}$	-	-	+/- 1.5	dB
Input return loss	S_{11}	$f < 16 \text{ GHz}$	-	-	-10	dB
Output return loss	S_{22}	$f < 12 \text{ GHz}$	-	-	-10	dB
Isolation	S_{12}	$f < 20 \text{ GHz}$	-	-	-60	dB

Analog Mode

Parameter	Symbol	Conditions	Min	Typ	Max	Unit
Output power 1 dB compression	$P_{1\text{dB}}$	0 - 10 GHz 10 - 16 GHz	-	21 19	-	dBm
Saturated Output power	P_{sat}	$F < 10 \text{ GHz}$ $V_{\text{in}} \sim 0.6 V_{\text{PP}}$	-	-	23	dBm
Input power	P_{in}	-	-	-	0	dBm
Noise figure	NF	2 - 10 GHz	2	-	4	dB
Delay time	t_{d}	$f < 16 \text{ GHz}$	-	450	-	ps

Pulse Mode

Parameter	Symbol	Conditions	Min	Typ	Max	Unit
Pulse width	PW	-	50 p	-	300 n	s
Pulse repetition frequency	PRF	Depending on duty cycle	10	-	1 G	Hz
Input pulse amplitude	V_{in}	Square pulse	-	0.18	0.35	V_{PP}
		Pulse shaping	-	-	0.12	
Rise / Fall time	$t_{\text{r}}/t_{\text{f}}$	20 % - 80 %	-	22/22	24/24	ps
Output pulse amplitude	V_{out}	$V_{\text{in}} \sim 0.2 V_{\text{PP}}$	-	-	8	V_{PP}

DR-VE-10-MO

VErsatile RF amplifier module Driver

Digital Mode

Parameter	Symbol	Conditions	Min	Typ	Max	Unit
Data rate	-	-	0.1	-	14	Gb/s
Input eye amplitude	V_{in}	-	-	0.2	1	V_{pp}
Output eye amplitude (user adjustable)	V_{out}	$V_{in} \sim 0.2 V_{pp}$	2.5	6	8	V_{pp}
Saturated output eye amplitude	$V_{out_{sat}}$	$V_{in} \sim 0.25 V_{pp}$	-	-	8.5	V_{pp}
Eye cross point (user adjustable)	Xp	-	45	50	55	%
Output Jitter, RMS value	J_{RMS}	$J_{RMS} = \sqrt{J_{OUT}^2 - J_{IN}^2}$	-	0.8	1.1	ps
Rise Time / Fall Time	t_r/t_f	20 % - 80 %	-	20/20	22/22	ps
Q Factor	Q	$V_{out} \sim 6 V_{pp}$	23	28	-	-

Power supply

Parameter	Symbol	Min	Typ	Max	Unit
Supply voltage	V_{bias}	-	12	15	V
Supply current	I_{bias}	-	-	450	mA
Power dissipation	P_{diss}	-	-	6.7	W
Operating temperature	T_{op}	0	-	+40	°C

DR-VE-10-MO

Test conditions: Output amplitude = 70 %, Gain = 40 %, Crosspoint = 60 %, 12 V, 300 mA

S_{21} Parameter Curve

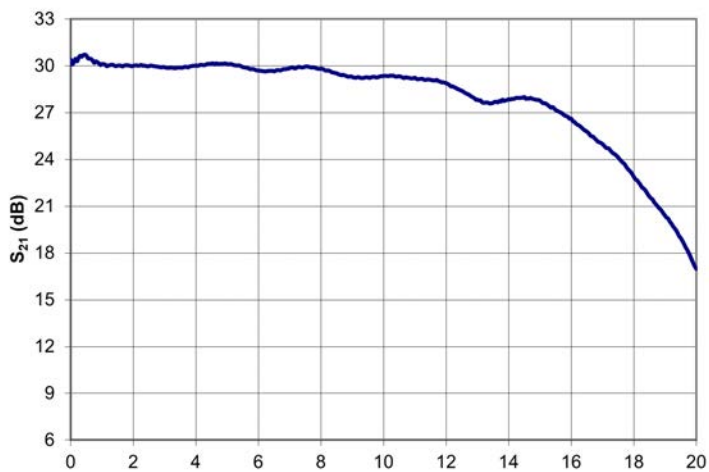

S_{11} Parameter Curve

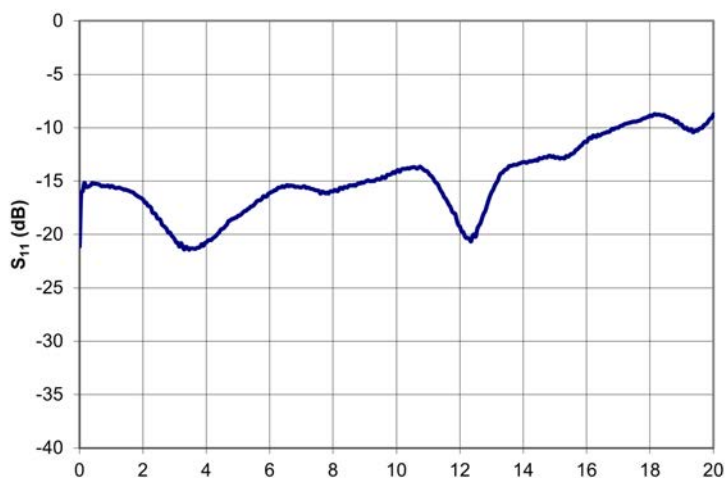

S_{12} Parameter Curve

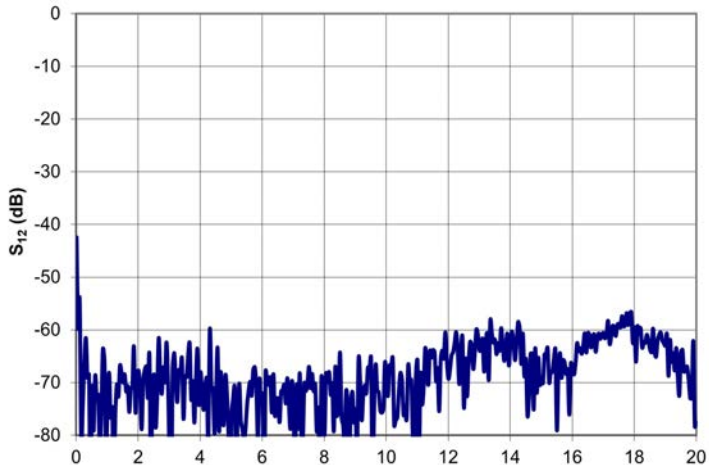

S_{22} Parameter Curve

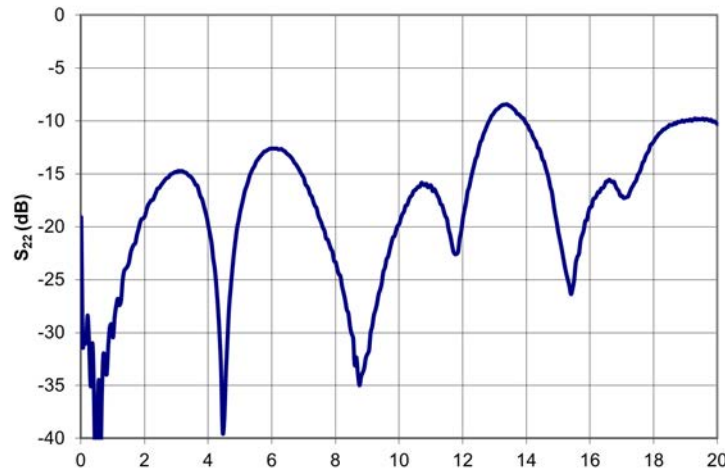

P1 dB Parameter Curve

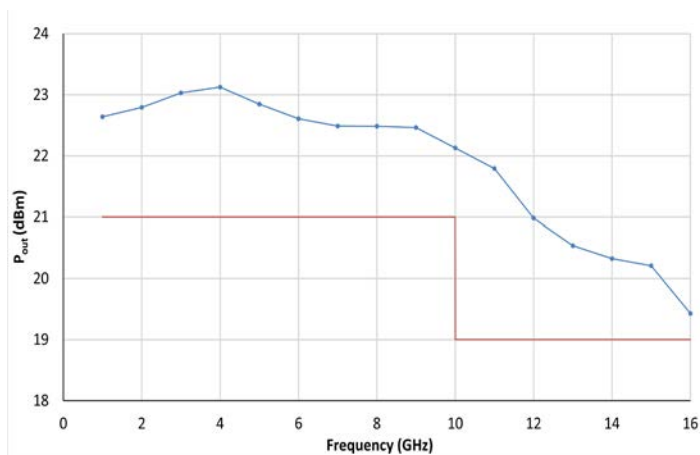

DR-VE-10-MO

Pulse measurement (Pulse mode, square pulse, $0.18 \text{ Vpp} < V_{in} < 0.35 \text{ Vpp}$)

Test conditions depends on Pulse sign (\square or \sqcap)

Output pulse 50 ps

Pulse \square , $V_{in} = 180 \text{ mV}_{pp}$

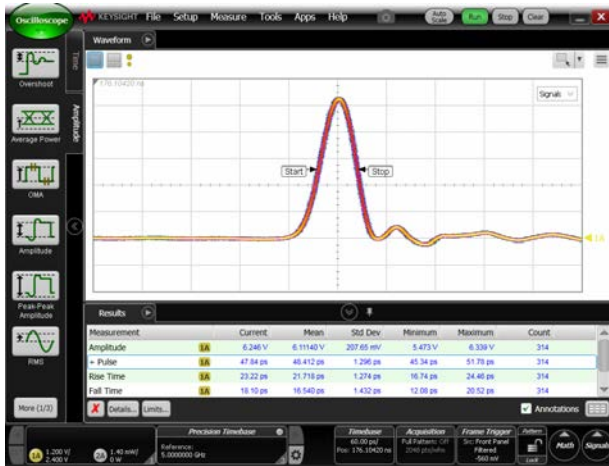

Pulse \sqcap , $V_{in} = 180 \text{ mV}_{pp}$

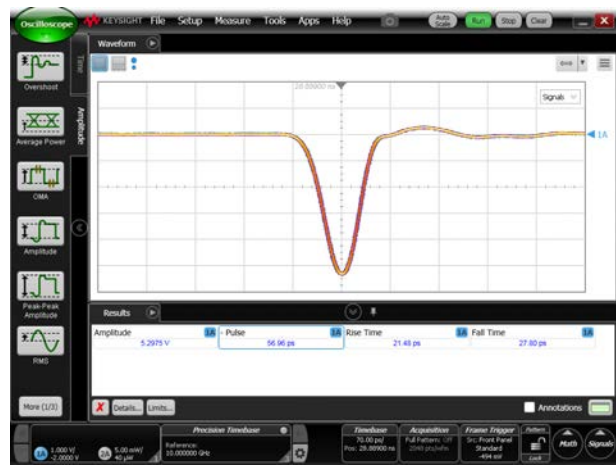

Output pulse 1 ns



Output pulse 5 ns



DR-VE-10-MO

Output pulse 100 ns



Output pulse 200 ns



DR-VE-10-MO

Linear Operation (Pulse mode, pulse shaping, $V_{in} < 0.12 V_{pp}$)

Pulse \square , $V_{in} \sim 90 \text{ mV}_{pp}$

Pulse \square , $V_{in} \sim 90 \text{ mV}_{pp}$

Ramp

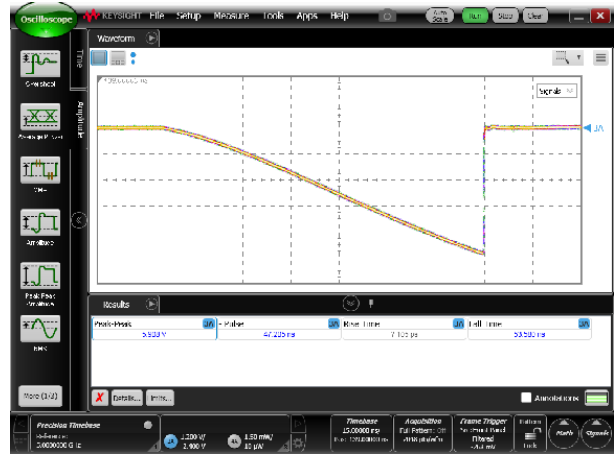
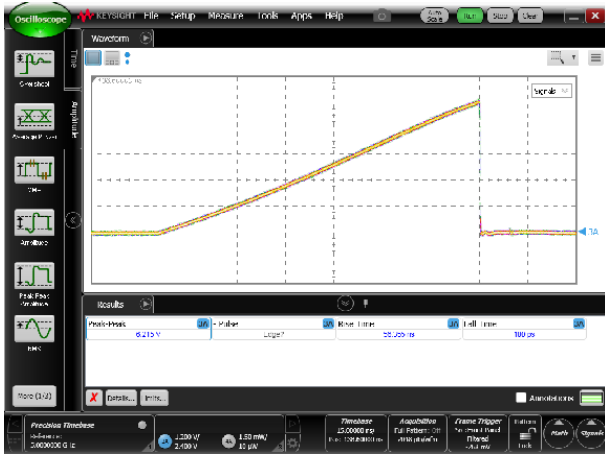

Exponential

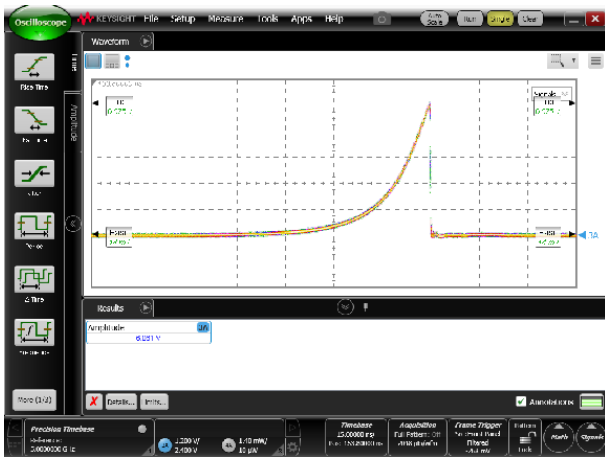

Pulse Train with Triangle envelope

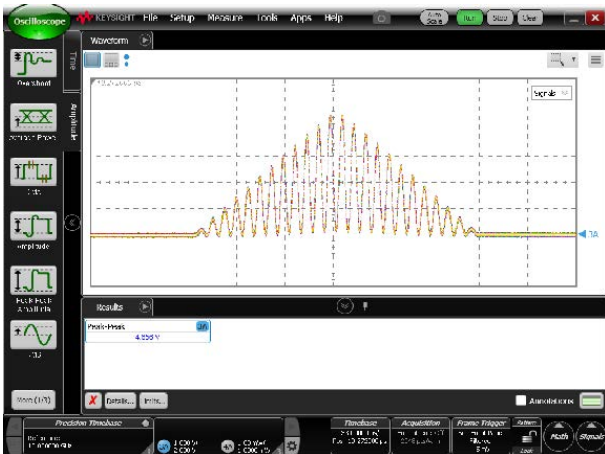

DR-VE-10-MO

Digital measurement:

Test conditions: Output amplitude = 45 %, Gain = 30 %, Crosspoint = 55 %, 12 V, 280 mA

Data Rate = 100 Mb/s, $V_{in} = 220\text{ mV}_{pp}$



Data Rate = 1 Gb/s, $V_{in} = 220\text{ mV}_{pp}$



Data Rate = 10 Gb/s, $V_{in} = 220\text{ mV}_{pp}$

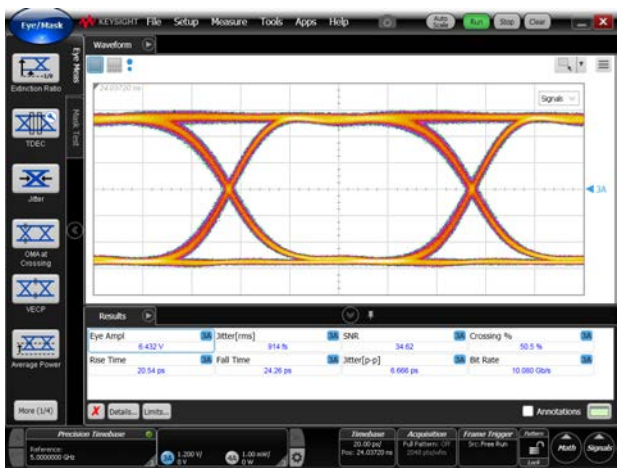

Data Rate = 14 Gb/s, $V_{in} = 220\text{ mV}_{pp}$

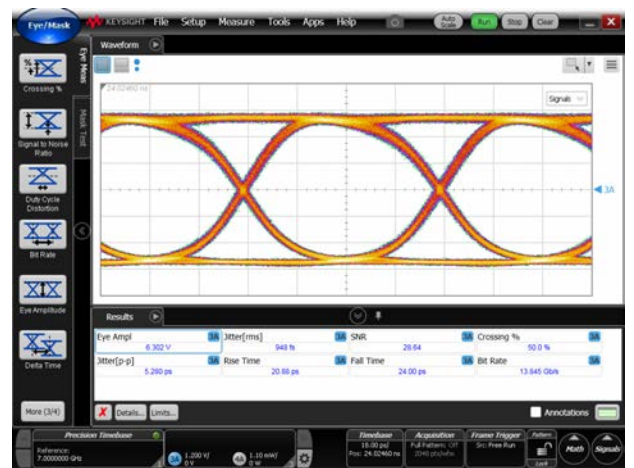

Mechanical Diagram and Pinout

All measurements in mm

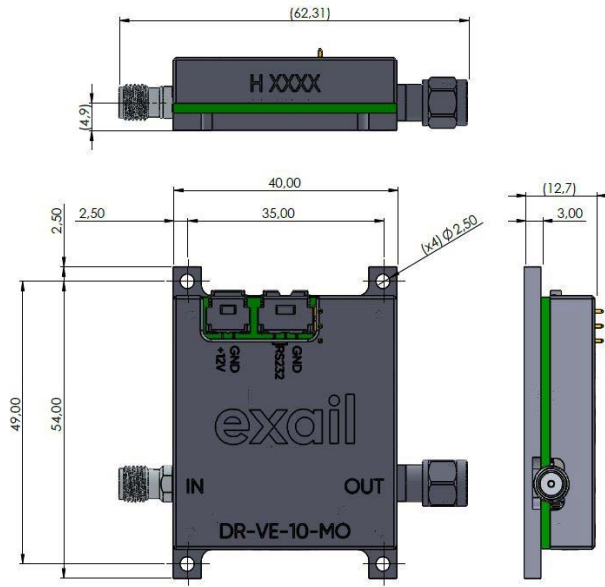

Mechanical Diagram and Pinout with HS-MO5

All measurements in mm

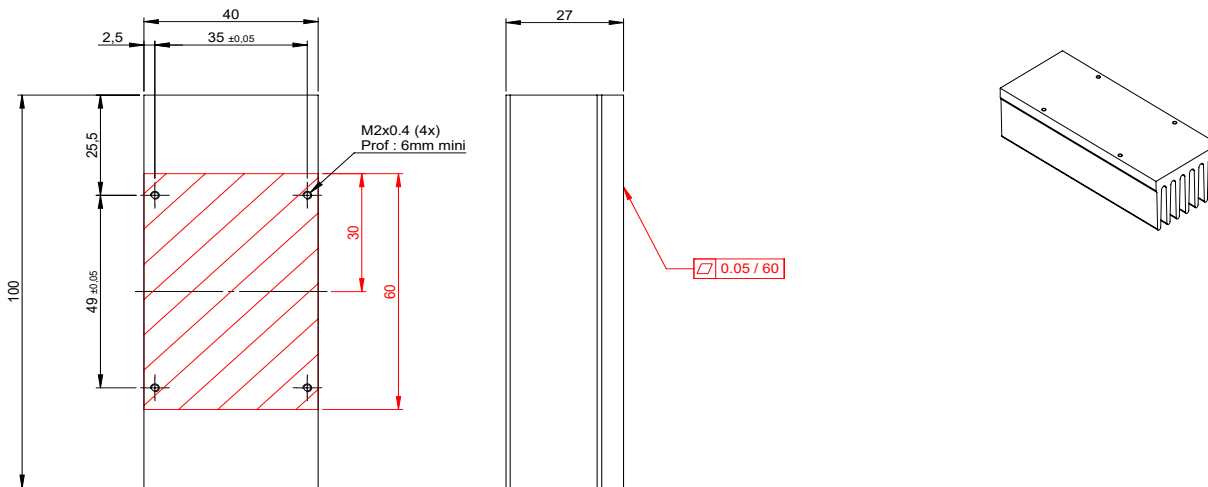

PIN	Function	Unit
Input connector	-	SMA Female
Output connector	-	SMA Male
Dimensions	Without connectors	40 mm x 54 mm x 12.7 mm

Driver Control Application

