

MODULATOR

NIR-MPX and NIR-MPZ Series

1000 nm band Phase Modulators

The Exail NIR-MP series are phase modulators especially designed to operate in the 1000 nm wavelength band. They are available with various modulation bandwidths, from low frequency to 30 GHz and beyond. Like all Exail Near InfraRed (NIR) modulators, the NIR-MP series use a proton exchange based waveguide process that confers them an unparalleled stability even when operating at high optical power and large range of temperatures. The NIR-MP phase modulators come with high Polarization Extinction Ratio (PER), Low Insertion Loss (LIL), Low V_{π} (LVP) and DC Coupled (DCC) options.



Features

- High optical power up to 25 dBm
- High bandwidth version > 30 GHz
- High stability vs optical power
- Low V_{π}
- Low insertion loss

Applications

- Interferometric based sensors
- Spectral broadening
- Laser combining
- Pound-Drever-Hall locking (PDH)
- Optical comb

Options

- Low IL, High PER, Low V_{π} (LVP)
- Lower Residual Amp Mod
- Space grade version (TRL9)

Related Equipments

- Matched RF amplifiers
- NIR-MX intensity modulators
- Spectral Broadening ModBox-SB
- CoherentBeamCombiningModBox-CBC

NIR-MPX-LN-0.1 Performance Highlights

Parameter	Min	Typ	Max	Unit
Operating wavelength	950	-	1150	nm
Usable EO bandwidth	-	300	-	MHz
V_{π} RF @50 kHz	-	1.5	-	V

NIR-MPX-LN-02 Performance Highlights

Parameter	Min	Typ	Max	Unit
Operating wavelength	950	-	1150	nm
Usable EO bandwidth	-	5	-	GHz
V_{π} RF @50 kHz	-	1.5	-	V

NIR-MPX-LN-05 Performance Highlights

Parameter	Min	Typ	Max	Unit
Operating wavelength	950	-	1150	nm
Usable EO bandwidth	-	10	-	GHz
V_{π} RF @50 kHz	-	4	-	V

NIR-MPZ-LN-10-LVP Performance Highlights

Parameter	Min	Typ	Max	Unit
Operating wavelength	950	-	1150	nm
Usable EO bandwidth	-	20	-	GHz
V_{π} RF @50 kHz	-	2	-	V

NIR-MPZ-LN-20 Performance Highlights

Parameter	Min	Typ	Max	Unit
Operating wavelength	950	-	1150	nm
Usable EO bandwidth	-	30	-	GHz
V_{π} RF @50 kHz	-	3.5	-	V

Ordering Information:



800 Village Walk #316
Guilford, CT 06437
Ph: 203-401-8093

Email orders to: sales@xsoptix.com
Fax orders to: 800-878-7282

NIR-MPX-LN-0.1

Up to 300 MHz Phase Modulator

Electrical Characteristics

Parameter	Symbol	Condition	Min	Typ	Max	Unit
Electro-optical bandwidth	S_{21}	-	150	-	-	MHz
Usable electro-optical bandwidth	t_r / t_f	-		300	-	MHz
V_{π} RF @50 kHz	$V_{\pi_{RF\ 50\ kHz}}$	RF electrodes	-	1.5	2	V
RF input impedance	Z_{in-RF}	-	-	10 000	-	Ω

Optical Characteristics

Parameter	Symbol	Condition	Min	Typ	Max	Unit
Crystal	-	-	Lithium Niobate X-Cut Y-Prop			
Waveguide process	-	-	Proton exchange			
Operating wavelength	λ	-	950	1060	1150	nm
Insertion loss	IL	Without connectors ⁽¹⁾	-	3	4	dB
Low insertion loss	LIL	Without connectors ⁽¹⁾	-	-	3	dB
Polarization Extinction ratio	PER	Standard, Without connectors ⁽¹⁾	20	-	-	dB
		Optional, w/ or w/o connectors ⁽²⁾	25	30	-	dB
Optical return loss	ORL	-	-40	-45	-	dB

All specifications given at 25 °C, 1060 nm, unless differently specified.

⁽¹⁾ Consider an extra-loss up to 0.4 dB for each FC/APC optical connector

⁽²⁾ High PER option

Absolute Maximum Ratings

Stresses in excess of the absolute maximum ratings can cause permanent damage to the device. These are absolute stress ratings only. Functional operation of the device is not implied at these or any other conditions in excess of those given in the operational sections of the data sheet. Exposure to absolute maximum ratings for extended periods can adversely affect device reliability.

Parameter	Symbol	Min	Max	Unit
RF input power (CW mode)	EP_{in}	-20	+20	V
Optical input power (CW mode)	OP_{in}	-	+25	dBm
Operating temperature	OT	0	+70	°C
Storage temperature	ST	-40	+85	°C

NIR-MPX-LN-02

Up to 5 GHz Phase Modulator

Electrical Characteristics

Parameter	Symbol	Condition	Min	Typ	Max	Unit
Electro-optical bandwidth	S_{21}	-	2	-	-	GHz
Usable electro-optical bandwidth	S_{21}	-	-	5	-	GHz
Ripple S_{21}	ΔS_{21}	-	-	0.5	1	dB
Electrical return loss	S_{11}	-	-	-10	-8	dB
V_{π} RF @50 kHz	$V_{\pi_{RF\ 50\ kHz}}$	-	-	1.5	2	V
RF input impedance	Z_{in-RF}	-	-	50	-	Ω

Optical Characteristics

Parameter	Symbol	Condition	Min	Typ	Max	Unit
Crystal	-	-	Lithium Niobate X-Cut Y-Prop			
Waveguide process	-	-	Proton exchange			
Operating wavelength	λ	-	950	1060	1150	nm
Insertion loss	IL	Without connectors ⁽¹⁾	-	3	4	dB
Low insertion loss	LIL	Without connectors ⁽¹⁾	-	-	3	dB
Polarization Extinction ratio	PER	Standard, without connectors ⁽¹⁾	20	-	-	dB
		Optional, w/ or w/o connectors ⁽²⁾	25	30	-	dB
Optical return loss	ORL	-	-40	-45	-	dB

All specifications given at 25 °C, 1060 nm, unless differently specified.

⁽¹⁾ Consider an extra-loss up to 0.4 dB for each FC/APC optical connector

⁽²⁾ High PER option

Absolute Maximum Ratings

Stresses in excess of the absolute maximum ratings can cause permanent damage to the device. These are absolute stress ratings only. Functional operation of the device is not implied at these or any other conditions in excess of those given in the operational sections of the data sheet. Exposure to absolute maximum ratings for extended periods can adversely affect device reliability.

Parameter	Symbol	Min	Max	Unit
RF input power (CW mode)	EP_{in}	-	+33	dBm
Optical input power (CW mode)	OP_{in}	-	+25	dBm
Operating temperature	OT	0	+70	°C
Storage temperature	ST	-40	+85	°C

NIR-MPX-LN-05

Up to 10 GHz Phase Modulator

Electrical Characteristics

Parameter	Symbol	Condition	Min	Typ	Max	Unit
Electro-optical bandwidth	S_{21}	-	5	-	-	GHz
Usable electro-optical bandwidth	S_{21}	-	-	10	-	GHz
Ripple S_{21}	ΔS_{21}	-	-	0.5	1	dB
Electrical return loss	S_{11}	-	-	-12	-10	dB
V_{π} RF @50 kHz	$V_{\pi_{RF} 50 \text{ kHz}}$	-	-	4	5	V
RF input impedance	Z_{in-RF}	-	-	50	-	Ω

Optical Characteristics

Parameter	Symbol	Condition	Min	Typ	Max	Unit
Crystal	-	-	Lithium Niobate X-Cut Y-Prop			
Waveguide process	-	-	Proton exchange			
Operating wavelength	λ	-	950	1060	1150	nm
Insertion loss	IL	Without connectors ⁽¹⁾	-	3	4	dB
Low insertion loss	LIL	Without connectors ⁽¹⁾	-	-	3	dB
Polarization Extinction ratio	PER	Standard, without connectors ⁽¹⁾	20	-	-	dB
		Optional, w/ or w/o connectors ⁽²⁾	25	30	-	dB
Optical return loss	ORL	-	-40	-45	-	dB

All specifications given at 25 °C, 1060 nm, unless differently specified.

⁽¹⁾ Consider an extra-loss up to 0.4 dB for each FC/APC optical connector

⁽²⁾ High PER option

Absolute Maximum Ratings

Stresses in excess of the absolute maximum ratings can cause permanent damage to the device. These are absolute stress ratings only. Functional operation of the device is not implied at these or any other conditions in excess of those given in the operational sections of the data sheet. Exposure to absolute maximum ratings for extended periods can adversely affect device reliability.

Parameter	Symbol	Min	Max	Unit
RF input power (CW mode)	EP_{in}	-	+33	dBm
Optical input power (CW mode)	OP_{in}	-	+25	dBm
Operating temperature	OT	0	+70	°C
Storage temperature	ST	-40	+85	°C

NIR-MPZ-LN-10-LVP

Up to 20 GHz Phase Modulator

Electrical Characteristics

Parameter	Symbol	Condition	Min	Typ	Max	Unit
Electro-optical (EO) bandwidth	S_{21}	-	10	12	-	GHz
Usable electro-optical bandwidth	S_{21}	-	-	20	-	GHz
Ripple S_{21}	ΔS_{21}	-	-	0.5	1	dB
Electrical return loss	S_{11}	-	-	-13	-10	dB
V π RF @50 kHz / 1 GHz	$V_{\pi_{RF\ 50\ kHz}}$	-	-	2	3	V
V π RF @10 GHz	$V_{\pi_{RF\ 10\ GHz}}$	-	-	3	4	V
V π RF @20 GHz	$V_{\pi_{RF\ 20\ GHz}}$	-	-	4	-	V
RF input impedance	Z_{in-RF}	-	-	50	-	Ω

Optical Characteristics

Parameter	Symbol	Condition	Min	Typ	Max	Unit
Crystal	-	-	Lithium Niobate Z-Cut Y-Prop			
Waveguide process	-	-	Proton exchange			
Operating wavelength	λ	-	950	1060	1150	nm
Insertion loss	IL	Without connectors ⁽¹⁾	-	3	4	dB
		Standard, without connectors ⁽¹⁾	20	-	-	dB
Polarization Extinction ratio	PER	Optional, w/ or w/o connectors ⁽²⁾	25	30	-	dB
Optical return loss	ORL	-	-40	-45	-	dB

All specifications given at 25 °C, 1060 nm, unless differently specified.

⁽¹⁾ Consider an extra-loss up to 0.4 dB for each FC/APC optical connector

⁽²⁾ High PER option

Absolute Maximum Ratings

Stresses in excess of the absolute maximum ratings can cause permanent damage to the device. These are absolute stress ratings only. Functional operation of the device is not implied at these or any other conditions in excess of those given in the operational sections of the data sheet. Exposure to absolute maximum ratings for extended periods can adversely affect device reliability.

Parameter	Symbol	Min	Max	Unit
RF input power (CW mode)	EP_{in}	-	+33	dBm
Optical input power (CW mode)	OP_{in}	-	+25	dBm
Operating temperature	OT	-30	+70	°C
Operating temperature variation rate	OT_{vr}	-	1	°C
Storage temperature	ST	-40	+85	°C

NIR-MPZ-LN-20

Up to 30 GHz Phase Modulator

Electrical Characteristics

Parameter	Symbol	Condition	Min	Typ	Max	Unit
Electro-optical bandwidth	S_{21}	-	16	20	-	GHz
Usable electro-optical bandwidth	S_{21}	-	-	30	-	GHz
Ripple S_{21}	ΔS_{21}	-	-	0.5	1	dB
Electrical return loss	S_{11}	-	-	-13	-10	dB
V_{π} RF @50 kHz	$V_{\pi_{RF50\text{ kHz}}}$	-	-	3.5	4	V
V_{π} RF @20 GHz	$V_{\pi_{RF20\text{ GHz}}}$	-	-	6	-	V
RF input impedance	Z_{in-RF}	-	-	50	-	Ω

Optical Characteristics

Parameter	Symbol	Condition	Min	Typ	Max	Unit
Crystal	-	-	Lithium Niobate Z-Cut Y-Prop			
Waveguide process	-	-	Proton exchange			
Operating wavelength	λ	-	950	1060	1150	nm
Insertion loss	IL	Without connectors ⁽¹⁾	-	3	4	dB
Low insertion loss	LIL	Without connectors ⁽¹⁾	-	2.5	3	dB
Polarization Extinction ratio	PER	Standard, without connectors ⁽²⁾	20	-	-	dB
Optical return loss	ORL	-	-40	-45	-	dB

All specifications given at 25 °C, 1060 nm, unless differently specified.

⁽¹⁾ Consider an extra-loss up to 0.4 dB for each FC/APC optical connector

⁽²⁾ High PER option

Absolute Maximum Ratings

Stresses in excess of the absolute maximum ratings can cause permanent damage to the device. These are absolute stress ratings only. Functional operation of the device is not implied at these or any other conditions in excess of those given in the operational sections of the data sheet. Exposure to absolute maximum ratings for extended periods can adversely affect device reliability.

Parameter	Symbol	Min	Max	Unit
RF input power (CW mode)	EP_{in}	-	+33	dBm
Optical input power (CW mode)	OP_{in}	-	+25	dBm
Operating temperature	OT	-30	+70	°C
Operating temperature variation rate	OT_{vr}	-	1	°C/min
Storage temperature	ST	-40	+85	°C
Vibration	Vib	MIL-STD-883J method 2007.3 - Test condition B		
Mechanical shock	Shock	MIL-STD-882J method 2002.5 - Test condition B		

MODULATOR | NIR-MPX/MPZ-LN SERIES | 7/7

Mechanical Diagram and Pinout

All measurements in mm

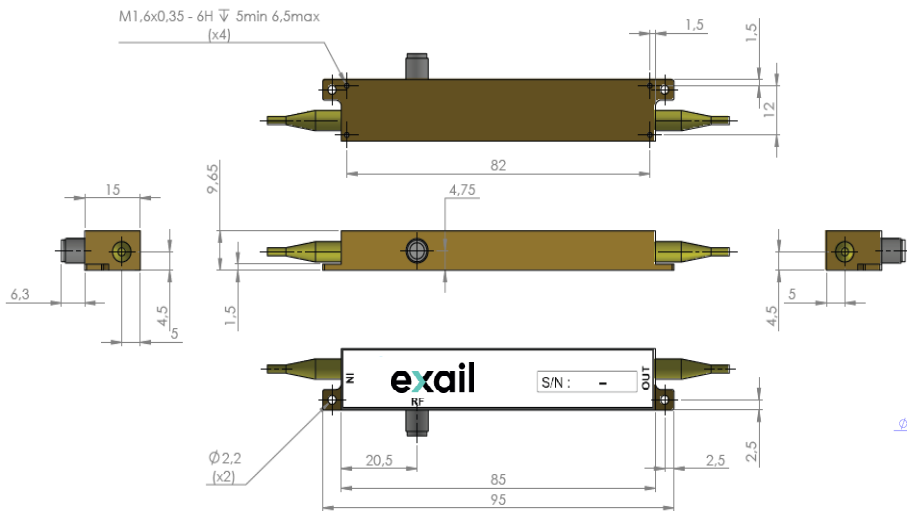

Housing #A: Standard Modulator housing

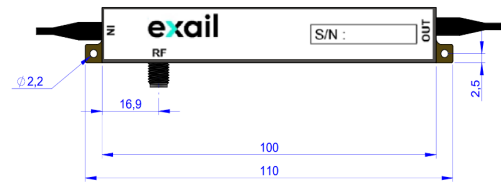

Housing #B: Modulator housing with LVP (NIR-MPZ-LN-10-LVP)

Port	Function	Note
IN	Optical input port	Polarization maintaining fiber Corning PM 98-U25D Length: 1.5 meter, buffer diameter: 900 μm
OUT	Optical output port	Polarization maintaining fiber Corning PM 98-U25D Length: 1.5 meter, buffer diameter: 900 μm
RF	RF input port	Female K

Ordering information

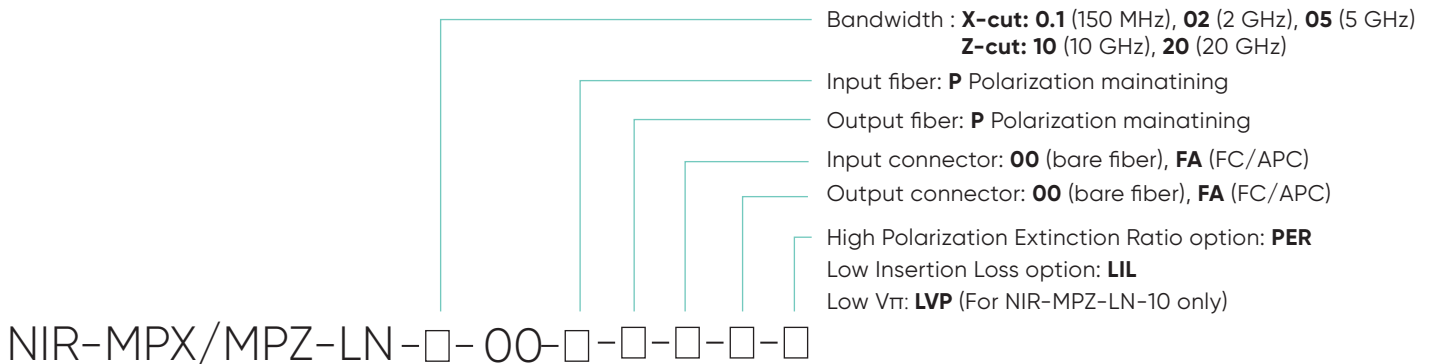

Exail reserves the right to change, at any time and without notice, the specifications, design, function or form of its products described herein.

contact.photonics@exail.com | www.exail.com
 Europe +33 1 30 08 87 43 | Americas +1 508 745 3487 | APAC +65 6747 4912

