



3910 Series RF Driver

USB Configurable AO Modulator Driver

Ordering Information:



800 Village Walk #316
Guilford, CT 06437
Ph: 203-401-8093
Email orders to: sales@xsoptix.com
Fax orders to: 800-878-7282

Operation Guide

The 3910 series RF driver configurability offer flexibility for optimum control of a wide variety of AO modulators, frequency shifters and pulse pickers.

The RF driver comes factory set to a specific frequency, amplitude modulation mode, and RF power. However, all of these parameters can be adjusted through the Driver's USB port. In many cases, optimizing the performance of the AO device will require adjustment of some of these settings. Software is available on the G&H website to simplify making changes to the driver. It is available at:

<https://gandh.com/3910-series-rf-driver-control-software/>

There will be more on the GUI software later in this document. First, let's get more familiar with the Driver's connections:

24-28 VDC: The 3910 drivers will run on voltages from +24V - +28V. The voltage is regulated internally to the proper level. The input connector is a TNC jack. The amount of current required varies with RF power. Please consult Fig. A for more information. As a rule of thumb we recommend a 24V power supply with 1A of current capacity.

RF Output: An SMA jack connector is the output for the RF power. The RF output impedance is 50 ohms and is connected to the AO modulator. Always connect the RF output to an AO device (or a 50 Ohm load) prior to connecting power to the driver.

Running the RF driver into anything other than 50 Ohms can damage the driver.

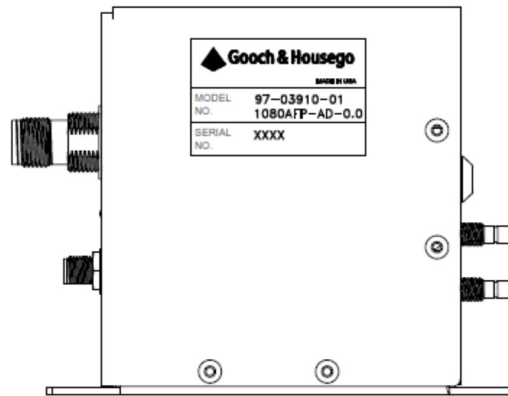

Key Features

- Up to 500MHz operating frequency
- Selectable modulation input
- Adjustable RF power up to 8 Watts
- Rise time as low as 4 ns
- Optional external clock synchronization

Key Benefits

- Proven reliability
- Consistent performance
- Lower power consumption
- Test documentation
- One year limited warranty

Applications

- Micromachining
- Materials processing
- Laser displays
- Printing
- Heterodyne interferometry
- Pulse picking

USB: The mini-B USB connector allows the user to alter the RF frequency, amplitude modulation mode and RF power level. All changes are automatically saved and will be remembered by the driver.

ANA MOD: Analog modulation port. This port has an SMB jack connector and accepts a 0-1V signal. The input impedance is 50 Ohms. The maximum RF output will occur at 1V and the minimum RF power at 0V. The RF output power will vary linearly as the voltage is changed between 0-1V.

DIG MOD: Digital modulation port. This port has an SMB jack connector and accepts both TTL (5V) and LVTTTL (3.3V) signals. The input impedance is 10k Ohms. The maximum RF power will occur at voltages above 2V and the minimum RF power will occur at voltages below 0.8V.

CLK: External clock. Some models are equipped with an external clock input. This option allows the driver to synchronize to an external clock signal. The parameters of the external clock are:

Input Frequency	10-250MHz
Input Sensitivity	$0.7 < V_{p-p} < 3.3V$
Input Capacitance	10 pF
Input Current	$\pm 60 \mu a$

Setup

Before powering up the driver, make sure to connect all of the appropriate cables. The RF output connects to the AO device. The modulation inputs need to be connected according to the modulation mode of the driver. If the modulation mode is Digital, only the digital port needs to be connected. If the modulation mode is Analog, only the analog modulation port needs to be connected. If the modulation mode is Combined, both the analog and digital modulation ports need to be connected. If the driver has an external clock, the external clock port needs to be connected to a valid clock signal. The USB port does not need to be connected for operation.

Startup Sequence

Once everything is connected properly, please follow the following startup sequence:

1. External clock (if configured)
2. +24V power
3. Wait until the green LED light comes on steady. This means that the driver has achieved lock.
4. Apply analog voltage (if configured)
5. Apply digital voltage (If configured)

Thermal Management:

Drivers that are producing 2.5W of RF power or below do not come with heat sinks attached. These drivers can be kept cool by mounting the base of the driver to a heat sink. The driver may also be mounted on its non-labelled side to a heat sink. Drivers producing more than 2.5 Watts come equipped with an external heat sink. The base of the driver should still be mounted to a heat sink. We also recommend applying forced air cooling at 100CFM to the heat sink. The temperature of the driver should not exceed 60°C. It is preferred to keep the temperature below 50°C.

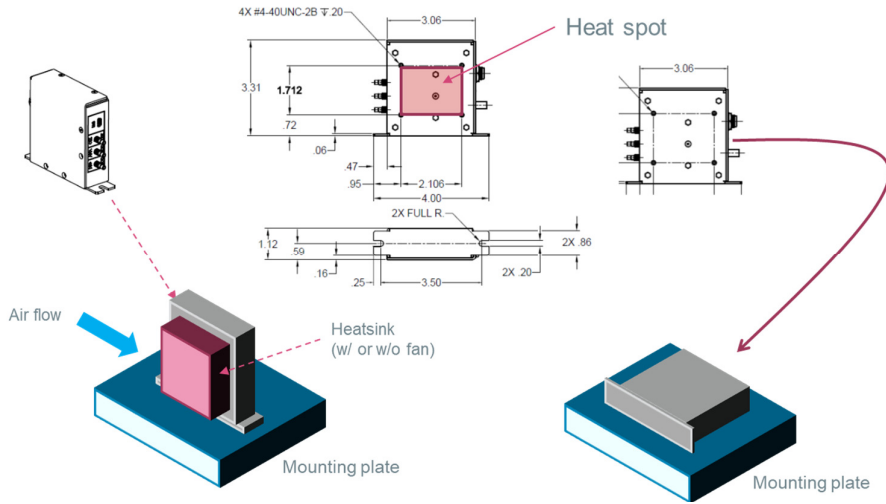

Cable Connection Guide:

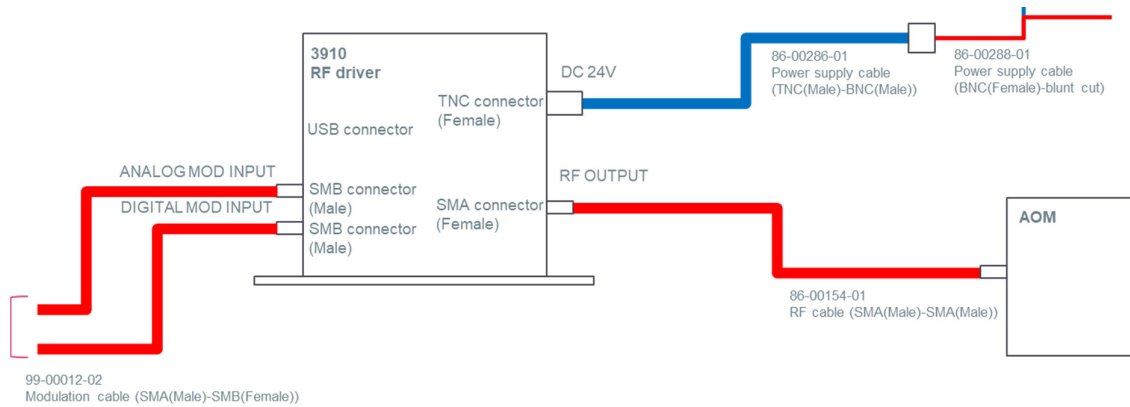

P/N	Description	Connector Type	Cable Type	Remarks
86-00286-01	Power supply cable	TNC (Male)-BNC(Male)	LMR-195 COAX, 1m	1.5m type is also available
86-00288-01	Supporting cable	BMC(Female)-blunt cut	Refer 'CT3264' more detail	
86-00154-01	RF cable	SMA(Male)-SMA(Male)	RG 174/U, 0.9m	Ask G&H for different length
99-00012-02	RF cable	SMA(Male)-SMB(Female)	RG 174/U, 1m	Ask G&H for different length

GUI Software Introduction:

Below is a sample screen shot of the GUI software. An operating system running Windows 10 is required.

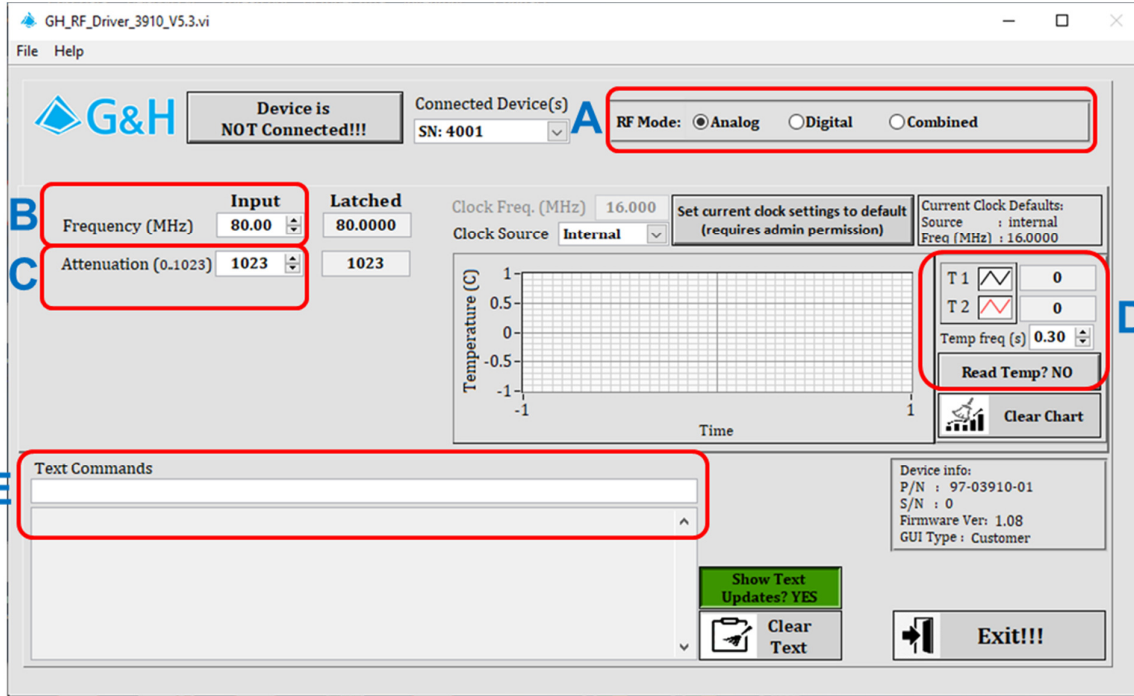

GUI Notes:

- A. RF Mode - Select between Analog, Digital or Combined Modulation modes
- B. Frequency - Enter the desired frequency.
- C. Attenuation - Set the RF power level (*lower* attenuation equates to *higher* power).
- D. Temperature - Read and chart internal temperatures.
- E. Text Commands - Enter text commands to control RF driver parameters.

Limitations / Restrictions:

Attenuation should only be adjusted $\pm 10\%$ of the factory setting. Adjustments outside of this range will affect the rise time of the device. Setting the attenuation below 600 may cause damage to the driver or AO device.

Any frequency adjustment made should stay within the following bands:

97-03910-XX / 97-03940-XX / 97-03950-XX / 97-03960-XX	35 - 150 MHz
97-03911-XX / 97-03941-XX / 97-03951-XX / 97-03961-XX	100 - 199 MHz
97-03912-XX / 97-03942-XX / 97-03952-XX / 97-03962-XX	200 - 350 MHz

Figure A: Typical Driver Current Consumption

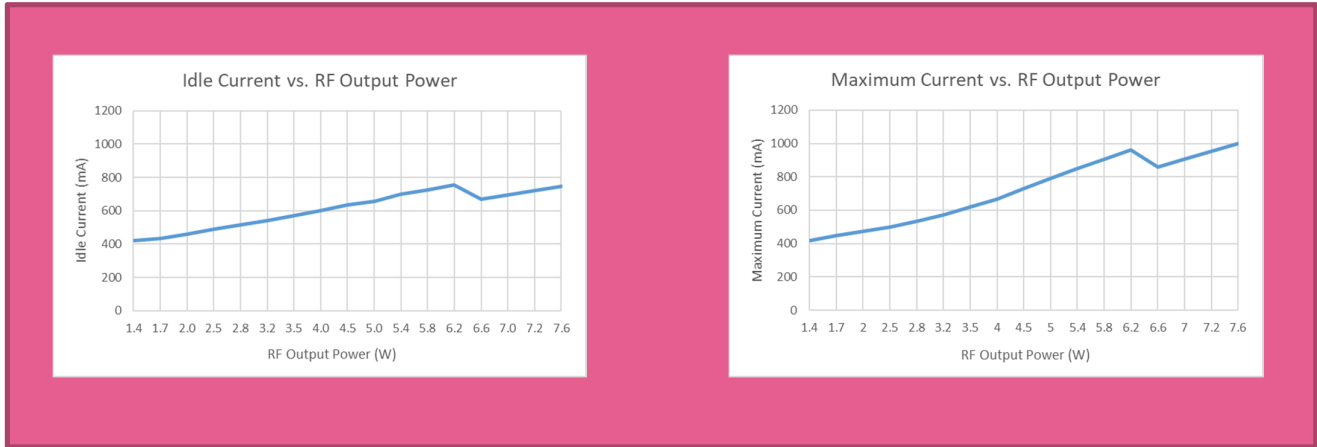

Note: Maximum current is drawn when the RF signal is on continuously (CW).

Figure B: Operating in Combined Mode:

Inputs

Analogue Modulation (normalized) 0-1V

Digital Modulation TTL

Output

RF Power out

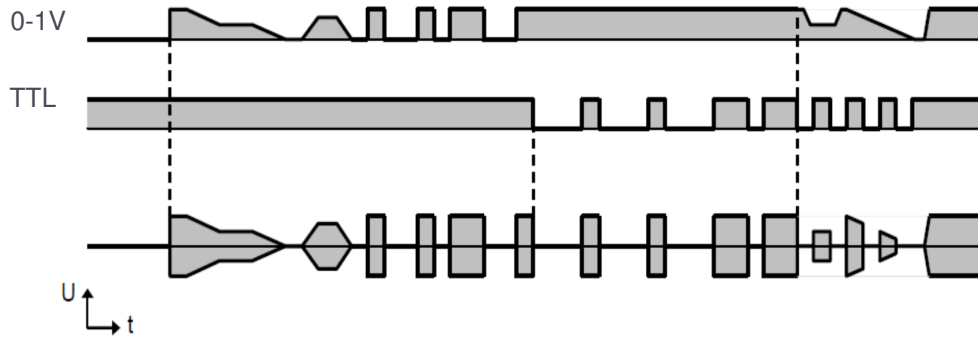

Note: Both Analog and Digital inputs need to be connected and used in Combined Mode.

3910 Driver Specifications:

Parameter	Performance
Center frequency	45 - 500 MHz fixed
RF output	0.25 - 8.0 Watts adjustable (at +28 V)
RF output stability	±5% over heat sink temperature range
Input voltage +Vcc	+24 to +28 V
2 nd harmonic level	< -20dBc
Output VSWR	1.5:1 max; 50 Ohms
Output waveform	Sinusoidal
Rise / fall time	4 nsec typ. (frequencies ≥ 200 MHz), 8 nsec Max
Contrast ratio	50 dB min
Analog input voltage	0 - 1 V
Analog input impedance	50 Ohms
Digital input voltage	TTL (5V) or LVTTL (3.3V) (VIH = 2.0V, VIL = 0.8V)
Digital input impedance	10 kOhms
Frequency stability	+/- 1.5 ppm over temp
Frequency accuracy	+/- 1.5 ppm
Jitter	0.3 psec typ.
Thermal management	Conduction cooled heat sink
Operating temperature range	10°C to 60°C (referenced to mounting tab)

Model Code Generation:

The model code will be entered as the description field.

Sample: 1200AFP-AD-2.5-EC40-24V

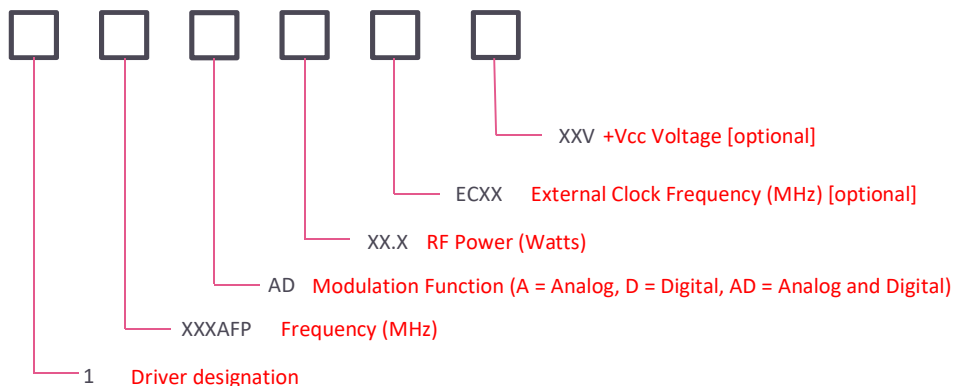

Outline Drawings:

Configuration with no external heatsink:

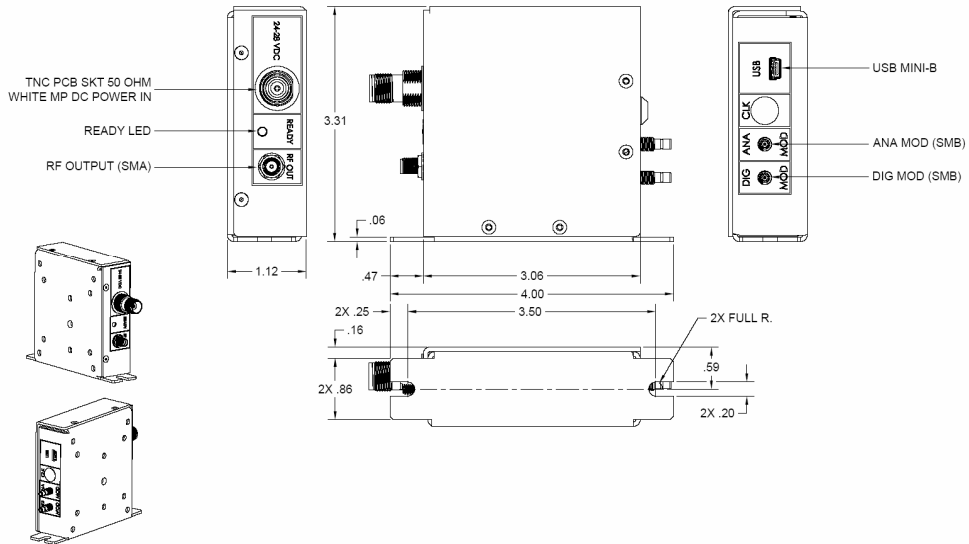

Configuration with external heatsink:

