

- NOTES: UNLESS OTHERWISE SPECIFIED
1. DRAWING PREPARED IN ACCORDANCE WITH MIL-STD-100.
 2. DIMENSIONING AND SYMBOLS PER ASME Y14.5M-1982.
 3. INTERPRET 3RD ANGLE PROJECTION.
 4. SEE CHART FOR SPECIFIC MODEL AND AVAILABLE CONNECTIONS.

REVISIONS				
ZONE	REV.	DESCRIPTION	CHNG / DATE	APVD / DATE
	C	CHANGE PER ECO 58A18390	RS 10/11/05	CAM 10/19/05

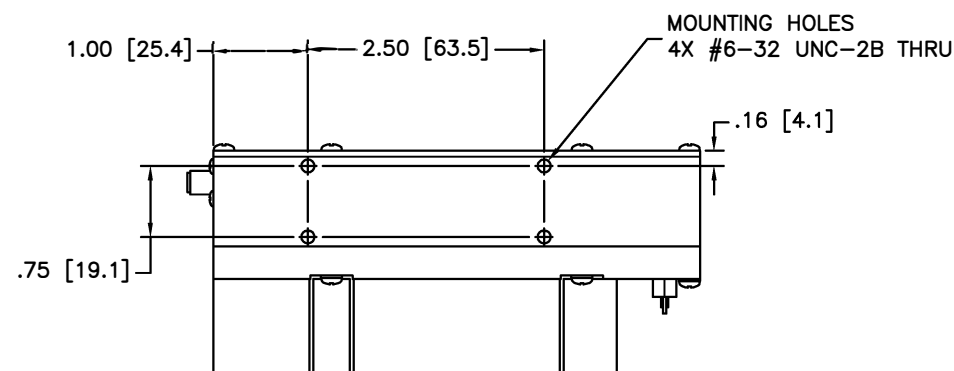
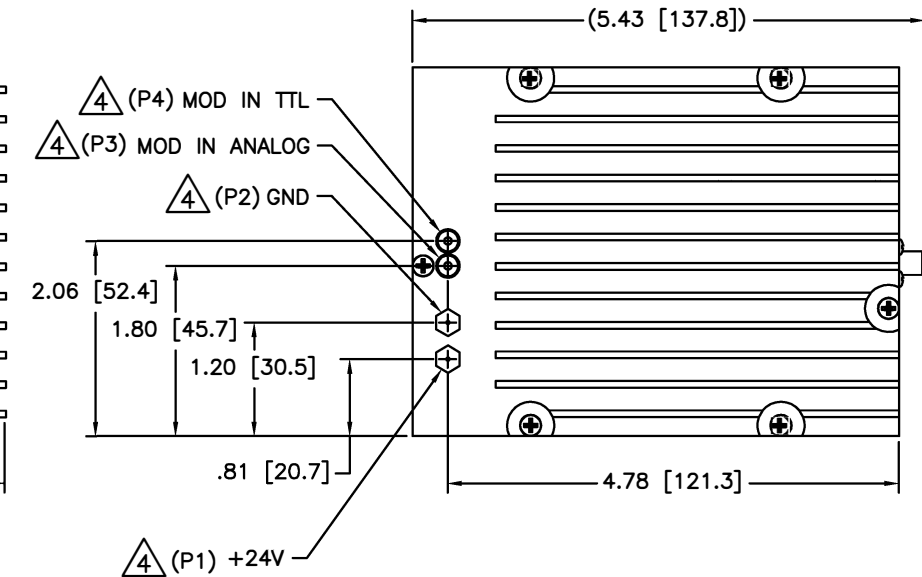
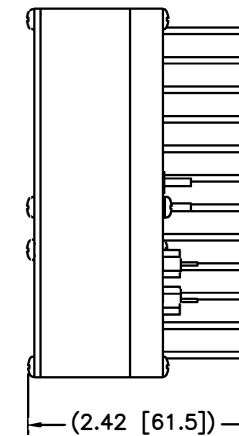
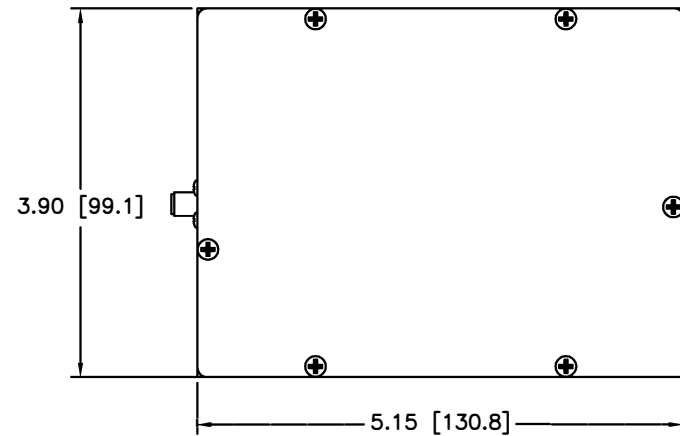
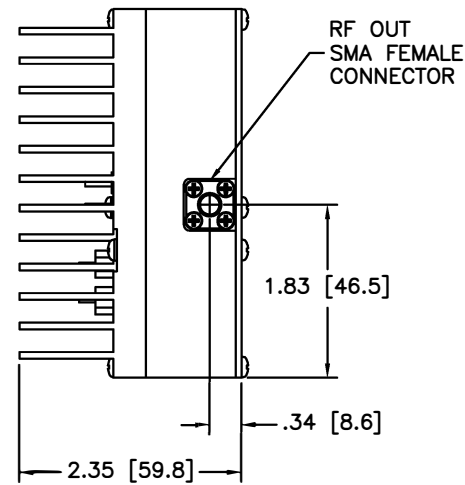
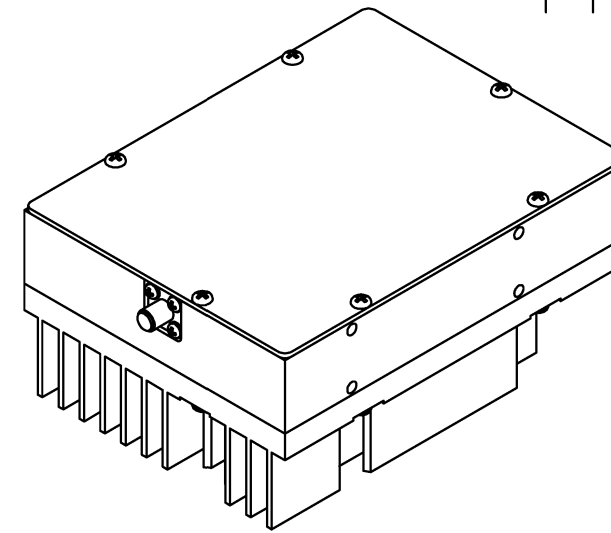
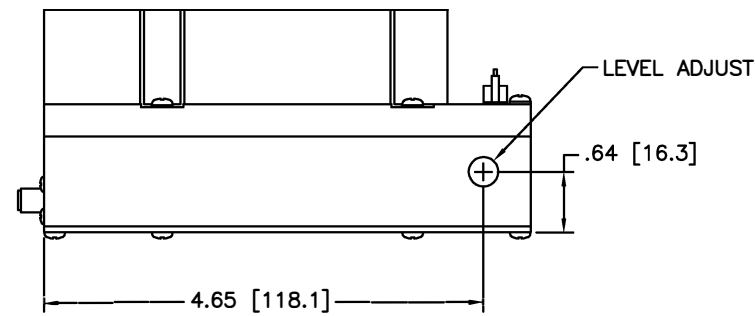

MODEL	AVAILABLE CONNECTIONS			
	P1	P2	P3	P4
31XXX-XDM-	X	X		X
31XXX-XAM-	X	X	X	
31XXX-XADM-	X	X	X	X

Ordering Information:



800 Village Walk #316
 Guilford, CT 06437
 Ph: 203-401-8093

Email orders to: sales@xsoptix.com
 Fax orders to: 800-878-7282

		MATERIAL	UNLESS OTHERWISE SPECIFIED DIMENSIONS ARE IN INCHES. DIMENSIONS AND VALUES IN BRACKETS ARE METRIC. TOLERANCES ARE: DECIMALS: INCHES MILLIMETERS .XX ±.02 [±.5] .XXX ± [±] ANGLES: ± SURFACE ROUGHNESS: REMOVE ALL BURRS AND SHARP EDGES. DIM. AND SURFACE ROUGHNESS APPLY AFTER COATING.	APPROVALS	DATE	 NEOS TECHNOLOGIES <small>A Gooch & Housego Company</small>		4005 OPPORTUNITY DRIVE MELBOURNE, FL 32934 (321) 242-7818 FAX: (321) 242-1019	
		FINISH		DRAWN BY: F. COLLETT CHECKED BY: ENGINEERING: JLL APPROVED: CMC	2/16/99 5/11/01 5/14/01	TITLE OUTLINE DRAWING 31XXX-XXX		SIZE D	DWG NO. 53D1597
NEXT ASSY	USED ON					SCALE	FILE	SHEET	
APPLICATION		DO NOT SCALE DRAWING				NONE	53D1597C	1 OF 1	