



Non contractual picture

## FEATURES

- Golden Reference Transmitter
- From 100 Mb/s up to 28 Gb/s
- Reliable & reproducible measurements
- High eye diagram stability
- Extinction Ratio Adjustable
- Burst Mode

## APPLICATIONS

- Transmission system test
- Components characterization
- Production test
- R&D laboratories

The ModBox-1310 nm-1550 nm BM-28Gb/s-NRZ is a two independent Channels Optical Reference Transmitter that generates excellent quality NRZ optical data streams from 100 Mb/s up to 28 Gb/s at 1310 nm and 1550 nm. The equipment incorporates two modulation stages each based on a chirp-free LiNbO<sub>3</sub> Mach-Zehnder modulator, coupled with a CW laser, a high performance RF driver, and an automatic bias control circuitry. Such set-up involves very clean eye diagrams with high SNR and short rise and fall times.

This ModBox is suitable for Ethernet PON (EPON) and standardized 10 Gb/s PON (XGPON) applications and receiver tests. Because of its higher bit rate capability to 28 Gb/s, it can be also used as a golden Optical Transmitter or as a tool to simulate network impairments for TIA and receiver testing in R&D or automated testing environments, characterize network components and devices.

This unit provides the flexibility of:

- adjusting the extinction ratio for vertical eye closure: two values are factory pre-set into the instrument. The user still has the capability to update any ER values as needed.
- adding horizontal impairments: the ModBox embeds a limiting amplifier to achieve high quality with sharp edges NRZ eye diagrams. The ModBox transposes stress magnitudes in the time domain coming from any jittering modulation generated by the PRBS.
- superimposing a burst mode: in addition to the high speed modulation rate, the ModBox embeds an independent (one per channel) lower speed modulation that switches optically the transmission ON and OFF.

## Performance Highlights

Parameter	Min	Typ	Max
Operating wavelength	1310 nm, 1550 nm		
Modulation format	NRZ from 100 Mb/s up to 28 Gb/s		
	Burst Mode up to 50 MHz		
Modulated output power	-	4 dBm	-
Pre-set extinction ratio	3 dB, 6 dB, 9 dB, 12 dB		

### Ordering Information:



800 Village Walk #316  
Guilford, CT 06437  
Ph: 203-401-8093

Email orders to: [sales@xsoptix.com](mailto:sales@xsoptix.com)  
Fax orders to: 800-878-7282

Functional Block Diagram

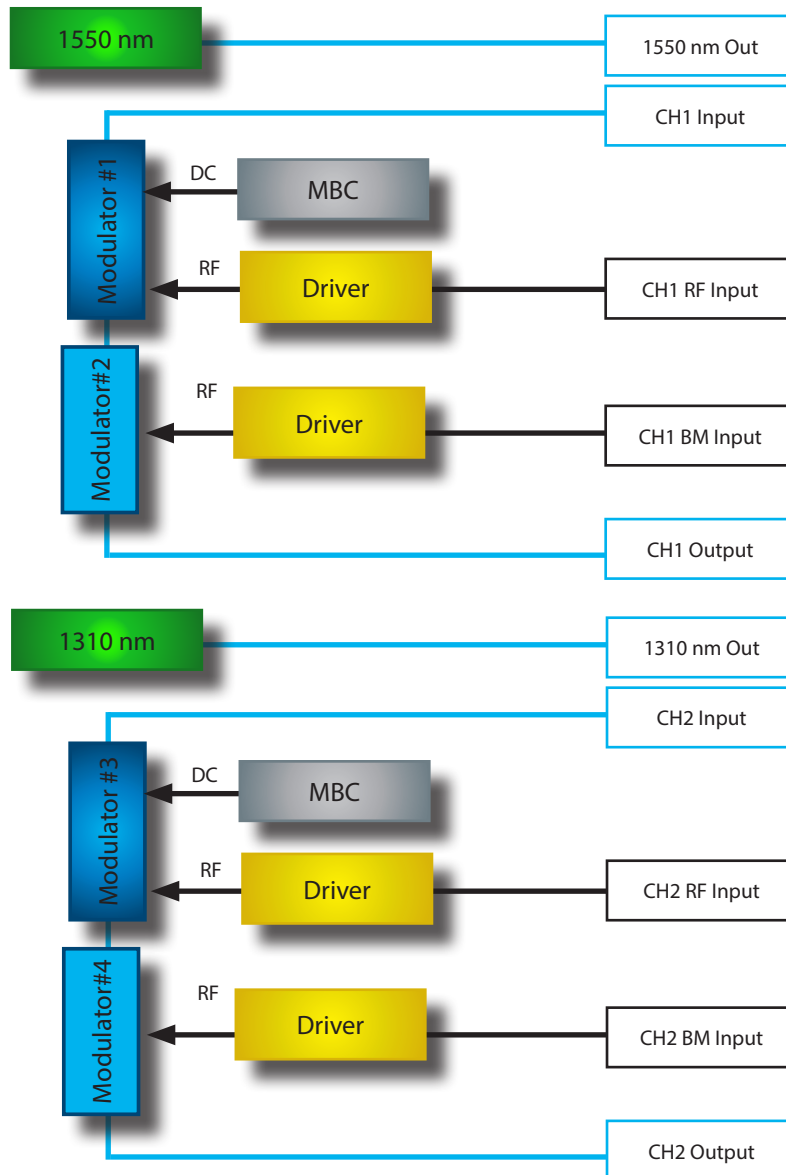

The ModBox-1310 nm-1550 nm-BM-28Gb/s-NRZ features:

- A chirp-free X-cut LiNbO<sub>3</sub> (Lithium Niobate) Mach-Zehnder Intensity modulator. It is selected for its high electro-optic bandwidth and flat, low ripple, electro-optic response curve.
- A high bandwidth limiting RF driver with gain and crossing levels adjustment for eye diagram optimization.
- A modulator bias controller. The internal LiNbO<sub>3</sub> modulator is a X-cut device with very low drift. Even though, an automatic bias control circuit is provided to lock the operating point of the modulator at the quadrature point whatever the environmental conditions. The MBC ensures a highly stable optical output signal to provide reliable and reproducible measurements.
- A 1310 nm-1550 nm low RIN lasers are integrated. Wavelength and power are tunable through the front panel controls or the ModBox software interface.

The ModBox is controlled from the front panel via the Smart interface with a simple rotary knob and keypad. The Smart manual interface allows for bias control circuit, driver gain and laser settings. It also comes with a windows based GUI that interfaces via USB with the ModBox.

## Electrical Input Specifications User supplied, not a ModBox specification

Parameter	Symbol	Condition	Min	Typ	Max	Unit
Main modulation						
Data-rate	PRBS	-	0.1	-	28	Gb/s
Input voltage	$V_{IN}$	CH1,2 RF Input	0.400	0.450	0.500	Vpp
Jitter	$J_{RMS}$	-	-	1	1.2	ps
Rise / fall time	$t_r / t_f$	20 - 80 % - @28Gb/s	-	13	18	ps
Cross-point	-	-	45	50	55	%
Burst Mode						
Switching voltage	$V_{IN}$	CH1,2 BM Input	-	3.3	-	Vpp
Frequency repetition rate	FRR	-	-	-	50	MHz

## Input Optical Specifications User supplied, not a ModBox specification

Parameter	Symbol	Condition	Min	Typ	Max	Unit
Operation	$\lambda$	CH1	1270	-	1330	nm
		CH2	1530	-	1570	nm
Polarization	-	-	Linear and controlled			-
Power	OP	1310 nm & 1550 nm	-	-	40	mW
Side Mode Supression Ratio	SMSR	-	30	-	-	dB
Spectrum linewidth	$\Delta\lambda$	FWHM	-	1	-	MHz

## Output Specifications

Parameter	Symbol	Condition	Min	Typ	Max	Unit
General						
Operation	$\lambda$	CW	Using internal lasers			-
Spectrum linewidth	$\Delta\lambda$	FWHM	-	1	-	MHz
Relative Intensity Noise	RIN	0.2 GHz - 3 GHz	-	-150	-	dB/Hz
Side Mode Supression Ratio	SMSR	-	30	-	-	dB
Max Average Output Optical Power <sup>(1)</sup>	Out	-	4	-	-	dBm
Optical Return Loss	ORL	-	30	-	-	dB
Electrical Return Loss	ERL	-	-	-10	-	dB
Main modulation						
Data-rate	PRBS	-	0.1	-	28	Gb/s
Added RMS Jitter	$J_{RMS}$	@25.78 Gb/s	-	0.8	1.2	ps
Variable Extinction Ratio	VER	Minimum	-	-	3	dB
		Maximum	12	-	-	dB
Pre-Set Extinction Ratio	PSER	1.25 Gbits (EPON)	3 dB, 6 dB, 9 dB, 12 dB			-
		2.48832 Gbits (XGPON)	3 dB, 6 dB, 9 dB, 12 dB			-
		10.3125 Gbits (EPON)	3 dB, 6 dB, 9 dB, 12 dB			-
		25.78 Gb/s	3 dB, 6 dB, 9 dB, 12 dB			-
Dynamic Signal to Noise Ratio	SNR	@25.78 Gb/s	15	20	-	-
Rise / fall time	$t_r / t_f$	@25.78 Gb/s	-	10	12	ps
Cross point	-	-	45	50	55	%
Eye cross point variation	-	-	-5	-	5	%
Burst Mode						
Mismatch	M	Between CH1,2 BM	-	100	200	ps
SWitching Time	SWT	-	-	-	10	ns
Burst repetition rate	BRR	-	0	-	30	MHz
Off-burst power levels	-	@1550 nm. Average Power <-1 dBm <sup>(2)</sup>	-	-	-45	dBm
	-	@1310 nm. Average Power <4 dBm <sup>(2)</sup>	-	-	-45	dBm

<sup>(1)</sup> For 80 mW laser input power

<sup>(2)</sup> The ACOMP's extinction ratio is wavelength dependent

Eye Diagrams - 10 Gb/s - 1310 nm



Eye Diagrams - 1 Gb/s - 1310 nm

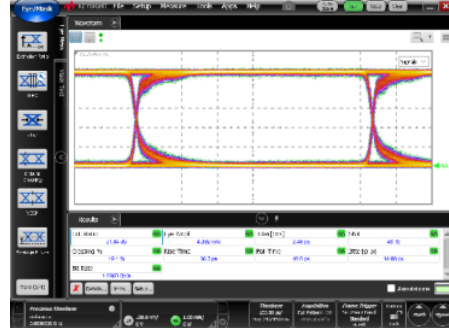

Eye Diagrams - 10 Gb/s - 1310 nm

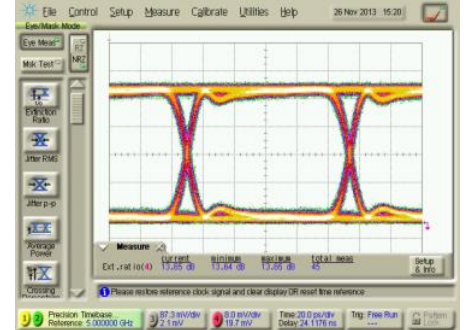
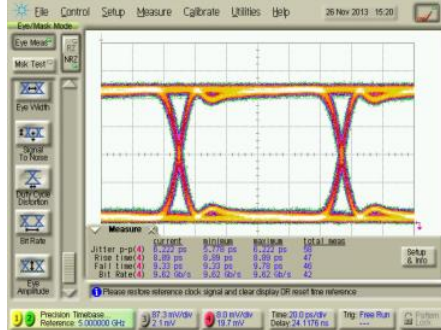
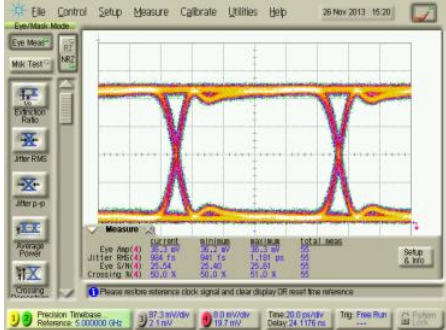

Eye Diagrams - 28 Gb/s - 1310 nm

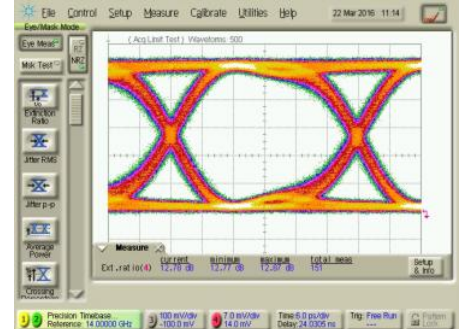
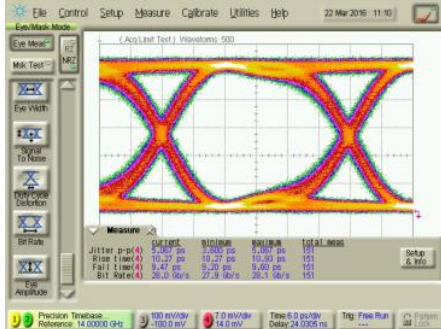
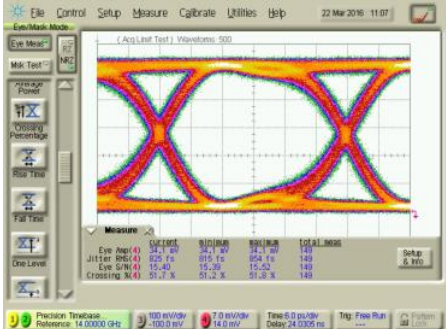

Eye Diagrams - 28 Gb/s with for different Extinction Ratio values

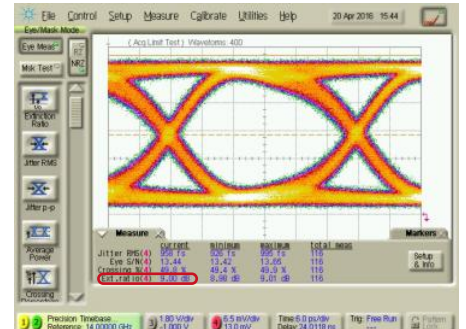
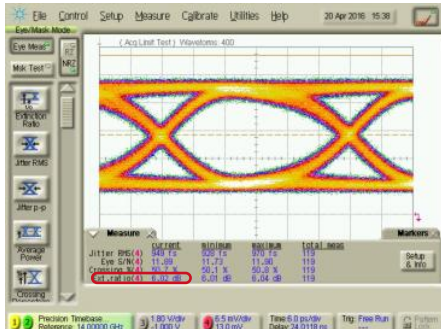
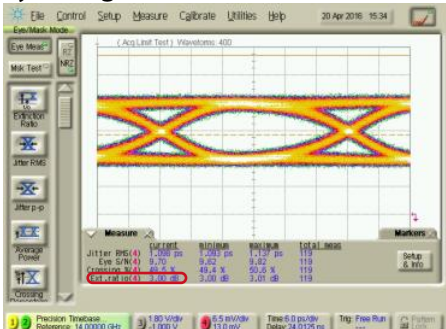

### Absolute Maximum Ratings

Stresses in excess of the absolute maximum ratings can cause permanent damage to the device. These are absolute stress ratings only. Functional operation of the device is not implied at these or any other conditions in excess of those given in the operational sections of the data sheet. Exposure to absolute maximum ratings for extended periods can adversely affect device reliability.

Parameter	Symbol	Condition	Min	Typ	Max	Unit
Input voltage	$V_{IN}$	CH1,2 RF Input	-	-	1	Vpp
Optical Input Power	$P_{IN}$	CH1,2 BM Input	-	-	20	dBm

### Interfaces, Dimensions and Compliance

Interfaces	
Optical	Polarization maintaining fiber PM1550 - FC/APC
CH1,2 RF input	AC coupled - 50 $\Omega$ - Single ended 1.85 mm female RF connector
CH1,2 BM input	50 $\Omega$ - Single ended - LVTTTL - SMA female RF connector - 50 $\Omega$
Control	Smart Interface (front panel), GUI (USB typeB)
Power supply	100-120V/220-240 automatic switch 50-60Hz (Rear panel)
EMC and optical norms	EN61326-1 Ed. 2006 / NF EN 60825-1 & EN 60825-2 Ed.2014



Non contractual picture

ModBox-1310nm-1550nm-BM-28Gbps-NRZ-Ed8 - QU\_2108\_39305

### About us

iXblue Photonics produces specialty optical fibers and Bragg gratings based fiber optics components and provides optical modulation solutions based on the company lithium niobate (LiNbO<sub>3</sub>) modulators and RF electronic modules.

iXblue Photonics serves a wide range of industries: sensing and instruments, defense, telecommunications, space and fiber lasers as well as research laboratories all over the world.