



The ModBox-VNA-850nm-976nm-40GHz is a wide bandwidth Optical Transmitter designed to extend Vectorial Network Analyzers applications into the optical domain.

When associated with a Vectorial Network Analyzer, they make up a high performance and easy to use test equipment for photoreceivers or any high speed optoelectronic device characterization.

The MModBox-VNA-850nm-976nm-40GHz incorporates an 850 nm and 976 nm low noise DBR lasers sources and a modulation stage based on a large bandwidth LiNbO<sub>3</sub> analog modulator with an automatic bias control circuit.

## FEATURES

- Analog modulation up to 40 GHz
- Embedded bias controller
- Low RIN
- High harmonics suppression

## APPLICATIONS

- Transmission system test
- Components characterization
- Receiver frequency test
- R&D laboratories

## OPTIONS

- C, L, O bands operation
- Multi-Channel

## Performance Highlights

Parameter	Min	Typ	Max
Operating wavelength	850	-	980
Embedded lasers	850 nm & 976 nm		
Modulation format	Analog Modulations		
Frequency	-	40 GHz	-

### Ordering Information:



800 Village Walk #316  
Guilford, CT 06437  
Ph: 203-401-8093

Email orders to: [sales@xsoptix.com](mailto:sales@xsoptix.com)  
Fax orders to: 800-878-7282

## Functional Block Diagram

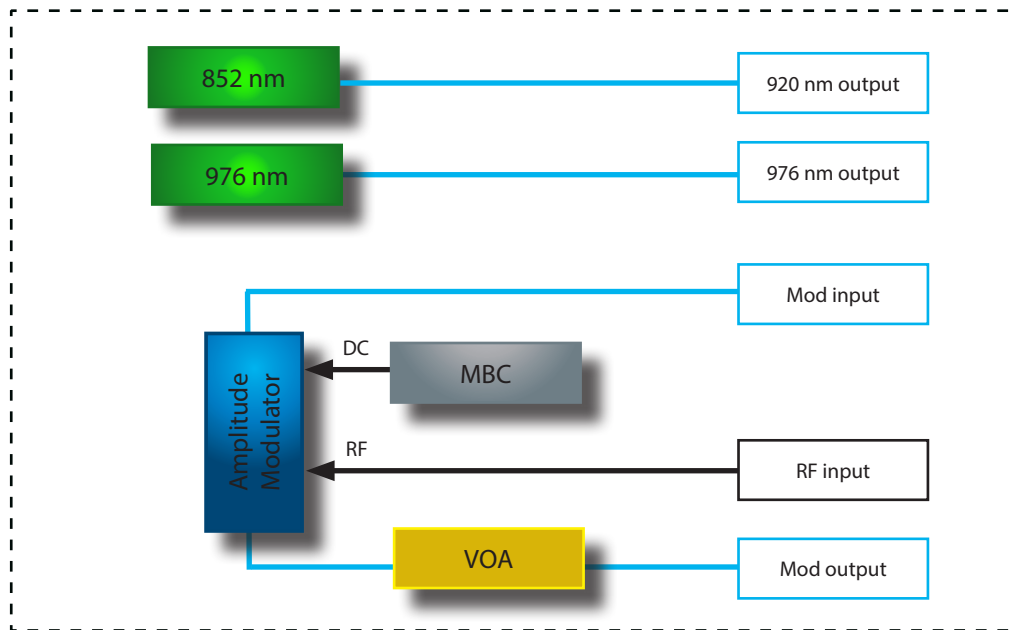

## The ModBox-VNA-850nm-976nm-40GHz features:

- A chirp-free X-cut LiNbO<sub>3</sub> (Lithium Niobate) Mach-Zehnder modulator for very high linearity and very wide electro-optical bandwidth.
- A modulator bias controller. The internal LiNbO<sub>3</sub> modulator is a X-cut device with very low drift. However an automatic bias control circuit (MBC) is provided to lock the operating point of the modulator at the quadrature point whatever the environmental conditions. The bias control circuit is based on dither tone. It is pre-set for operation in quadrature, in the linear portion of the modulator transfer curve. The system can operate over a large power dynamic range thanks to its software controllable gain parameters).
- Two lasers sources, an 852 nm 976 nm low RIN DBR lasers. For ease of use, an external patch cord is delivered to connect the laser output to the modulator input optical port. Wavelength and power are tunable through the front panel controls or the ModBox software interface.
- A Variable Optical Attenuator (VOA) to precisely control the modulated optical output signal.

## Input Optical Specifications User supplied, not a ModBox specification

Parameter	Symbol	Condition	Min	Typ	Max	Unit
Operating wavelength	-	CW	850	-	980	nm
Optical power	-	CW	7	-	16	dBm
Polarisation	Pol	-	Maintain and linear			-

## Input Electrical Specifications User supplied, not a ModBox specification

Parameter	Symbol	Condition	Min	Typ	Max	Unit
Input electrical termination	-	AC coupled	Single ended			-
Signal type	-	-	Analog, sine			-
Input voltage <sup>(1)</sup>	$V_{IN}$	Amplitude Modulation	-	100	-	mVpp
Bandwidth	BW	-	-	40	-	GHz
Impedance matching	$Z_{IN-RF}$	-	-	50	-	$\Omega$

(1): The ModBox-VNA-920nm-976nm-40GHz does not feature an internal RF amplifier. The VNA characterization is usually performed in a “small signal mode”, therefore a RF amplifier is not necessary. Omitting the amplifier allows to obtain a smoother and flatter transfer function.

## Output Optical Specifications

Parameter	Symbol	Condition	Min	Typ	Max	Unit
Modulation Frequency	-	-	-	40	-	GHz
Wavelength	$\lambda$	Embedded by default	852 nm & 976 nm			-
Wavelength laser tuning range	$\Delta\lambda$	Diode chip temperature control	-	0.8	1	nm
Modulated output power	$OP_{OUT}$	-	5	6	-	dBm
Optical output power adjustment	$\Delta OP_{OUT}$	By the use of the VOA	-40	-	6	dBm
Optical output power stability	$\delta OP_{OUT}$	Over 12 hours	-	-	1	%rms
Side Mode Supression Ratio	SMSR	-	40	45	-	dB
Spectrum linewidth	$\delta\lambda$	FWHM	-	3	15	MHz
Relative Intensity Noise	RIN	16 dBm	-	-	-163	dB/Hz
Polarization extinction ratio	PER	-	17	20	-	dB
Optical return loss	ORL	-	-40	-	-	dB
Electrical return loss	ERL	-	-	-12	-10	dB

## Absolute Maximum Ratings

Parameter	Symbol	Min	Max	Unit
RF input power	$EP_{in}$	-	28	dBm

Modulator [S] parameters

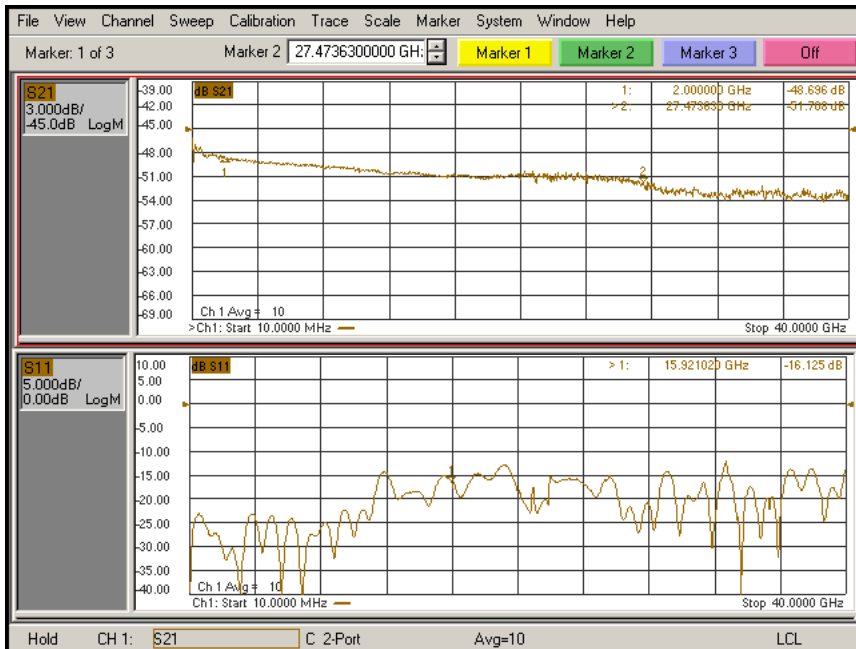

Modulator  $V_{\pi}$  versus frequency @850 nm

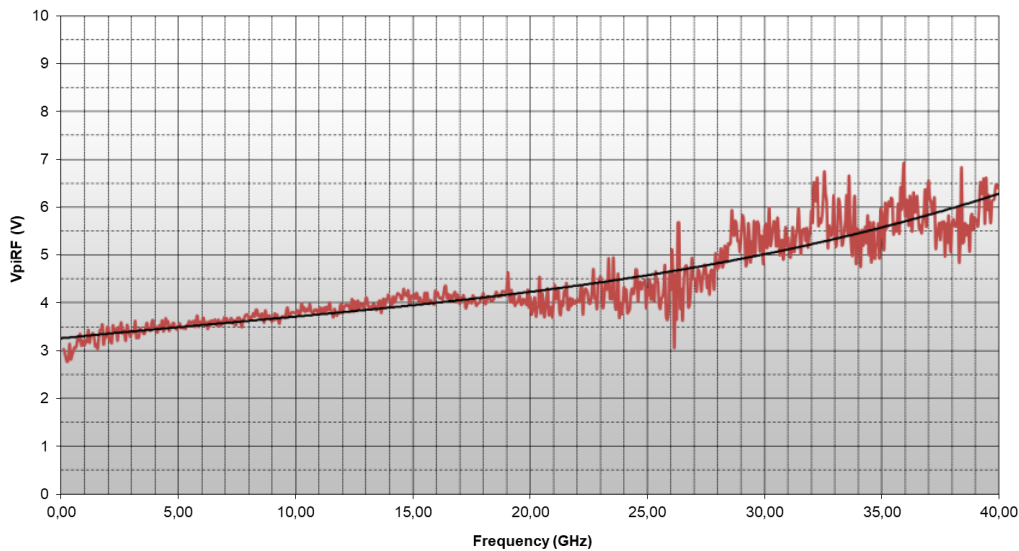

## Interfaces, Dimensions and Compliance

Interfaces	
Optical connectors and fibers	FC/APC - Polarization maintaining fiber Corning PM85-U25D
Electrical connector	V female (1.85 mm)
Control	Embedded Interface (front panel touchscreen) + Remote control (Ethernet)
Power supply	100 V - 120 V / 220 V - 240 V automatic switch 50 Hz - 60 Hz (Rear panel)
EMC / Optical norms	EN61326-1 Ed. 2006 / EN 60625-1
Dimensions / Weight	Rack 19" x 2U, Depth = 495 mm / 3 kg



## Ordering information

### ModBox-VNA-850nm-976nm-40GHz-FA

VNA = Optical Vectorial Network Analyser extension  
 850nm, 976nm = embeds laser, 852 nm & 976 nm  
 40GHz = Analog Modulation up to 40 GHz and beyond  
 FA = Optical connectors, FA : FC/APC

## About us

ixblue Photonics produces specialty optical fibers and Bragg gratings based fiber optics components and provides optical modulation solutions based on the company lithium niobate (LiNbO<sub>3</sub>) modulators and RF electronic modules.

ixblue Photonics serves a wide range of industries: sensing and instruments, defense, telecommunications, space and fiber lasers as well as research laboratories all over the world.